

MATERIALS OF CONSTRUCTION:
CARBON STEEL, BRASS, DUCTILE IRON

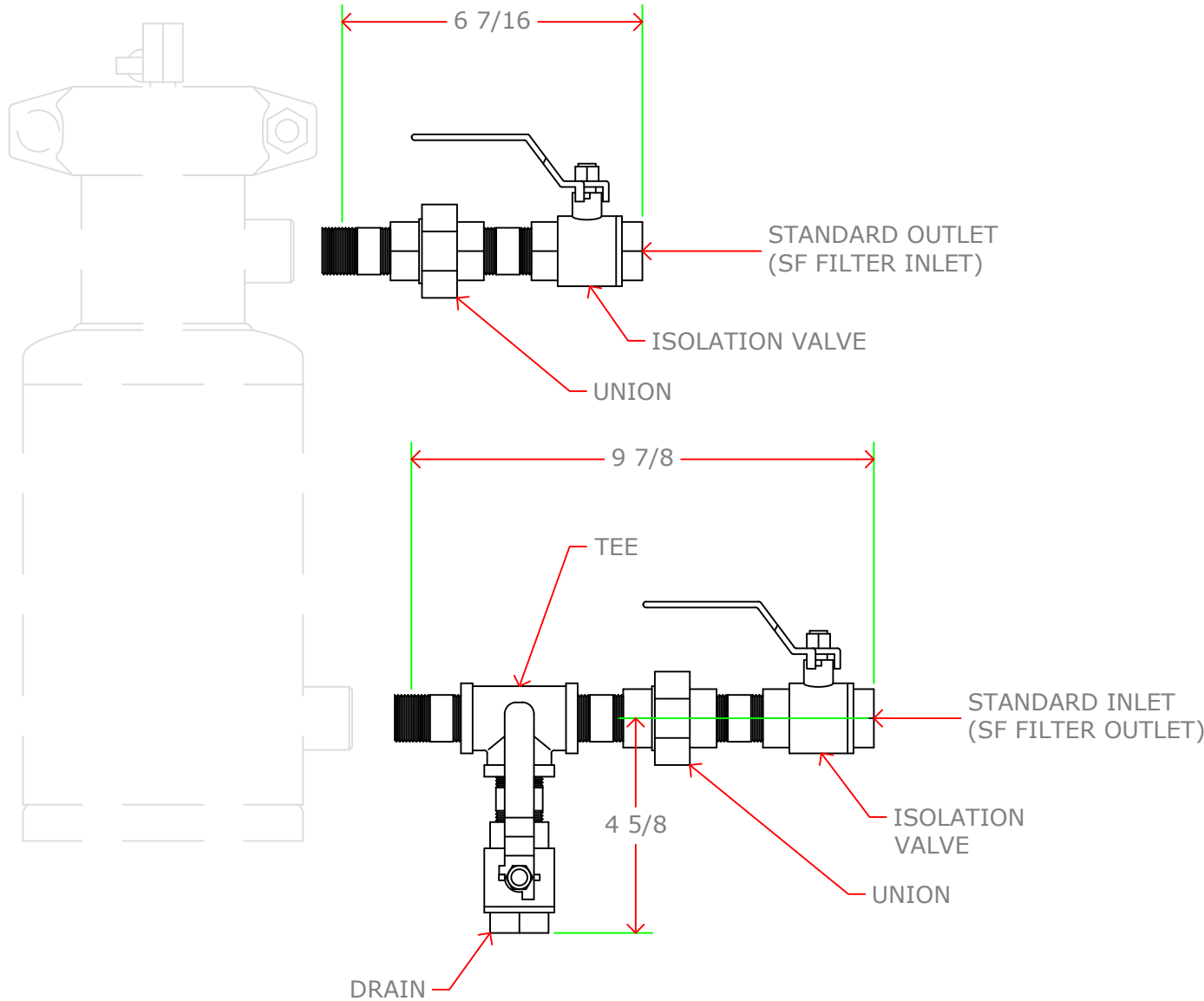

Capacity:	N/A	Gallons				
Max Temp.:	200	F				
Max Press.:	300	PSI				
Weight:	10	Lbs.				
Voltage.:	x	VAC	x	Phs	x	Hz
FLA.:	x	amps				

20	x	x
19	x	x
18	x	x
17	x	x
16	x	x
15	x	x
14	x	x
13	x	x
12	x	x
11	x	x
10	x	x
9	x	x
8	x	x
7	x	x
6	x	x
5	x	x
4	x	x
3	x	x
2	x	x
1	x	x

#	PART	DESCRIPTION
F	x	xx/xx/xx
E	x	xx/xx/xx
D	x	xx/xx/xx
C	x	xx/xx/xx
B	x	xx/xx/xx

REV	DESCRIPTION	DATE
-----	-------------	------

General Treatment Products, Inc.
PO Box 8697, Brea, CA 92822
Phone: 714) 257-9165 <http://www.gtpcompany.com>
Fax: 714) 257-9215 customerservice@gtpcompany.com

Date: 1/1/12 Scale: NTS Rev.: A

Description:
FLAT BOTTOM VALVE PACKAGE

Model:
VPFB



MATERIALS OF CONSTRUCTION:
 CARBON STEEL, BRASS, DUCTILE IRON

Capacity: N/A Gallons

Max Temp.: 200 F

Max Press.: 300 PSI

Weight: 10 Lbs.

20	x	x
19	x	x
18	x	x
17	x	x
16	x	x
15	x	x
14	x	x
13	x	x
12	x	x
11	x	x
10	x	x
9	x	x
8	x	x
7	x	x
6	x	x
5	x	x
4	x	x
3	x	x
2	x	x
1	x	x

#	PART	DESCRIPTION
F	x	xx/xx/xx
E	x	xx/xx/xx
D	x	xx/xx/xx
C	x	xx/xx/xx
B	x	xx/xx/xx

REV	DESCRIPTION	DATE
-----	-------------	------

General Treatment Products, Inc.
 PO Box 8697, Brea, CA 92822
 Phone: 714) 257-9165 <http://www.gtpcompany.com>
 Fax: 714) 257-9215 customerservice@gtpcompany.com

Date: 1/1/12 Scale: NTS Rev.: A

Description:
 DOME BOTTOM VALVE PACKAGES

Model:
 VPDB

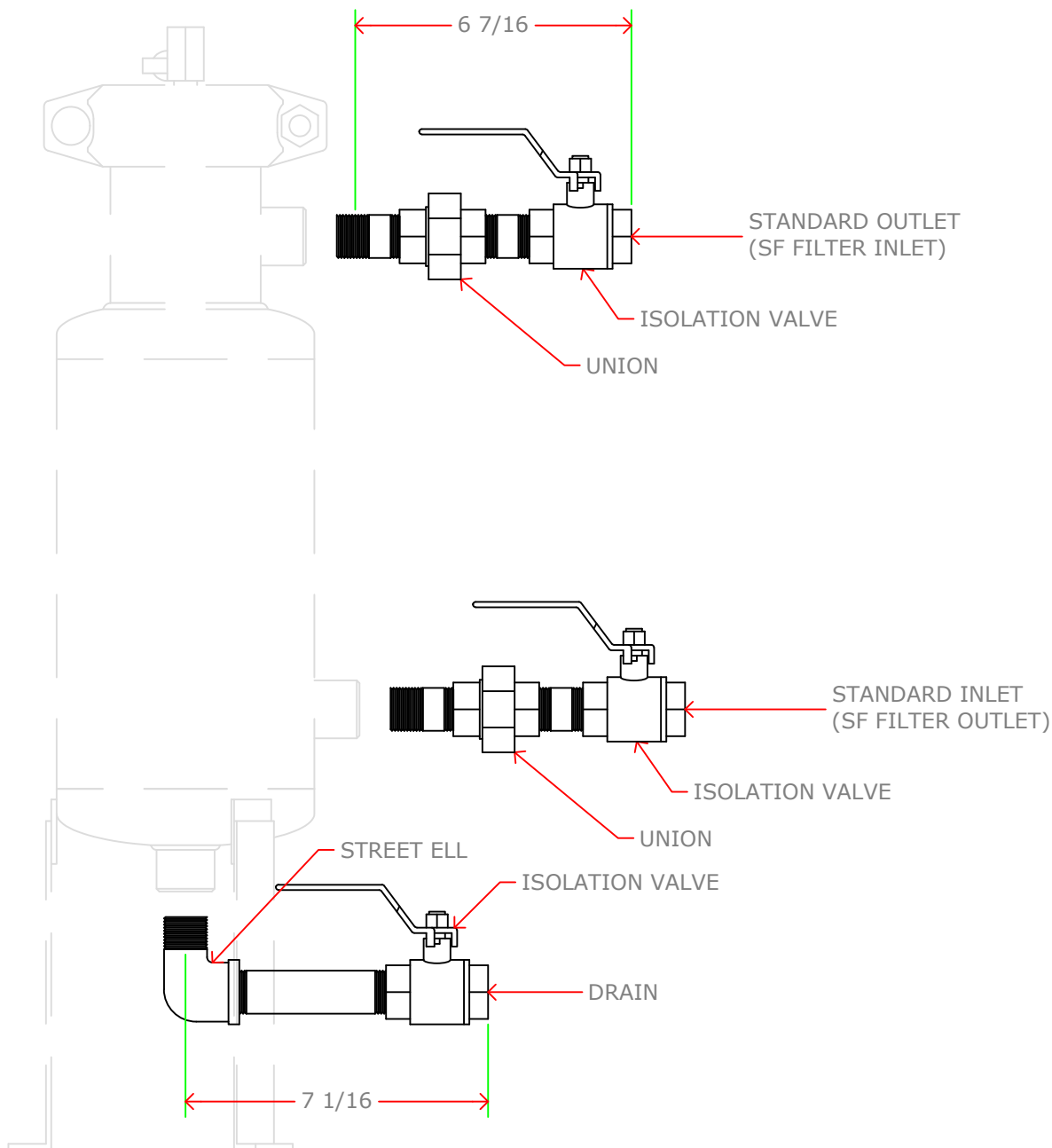



MATERIALS OF CONSTRUCTION:
 CARBON STEEL, BRASS, STAINLESS STEEL,
 BUTYL RUBBER HOSE

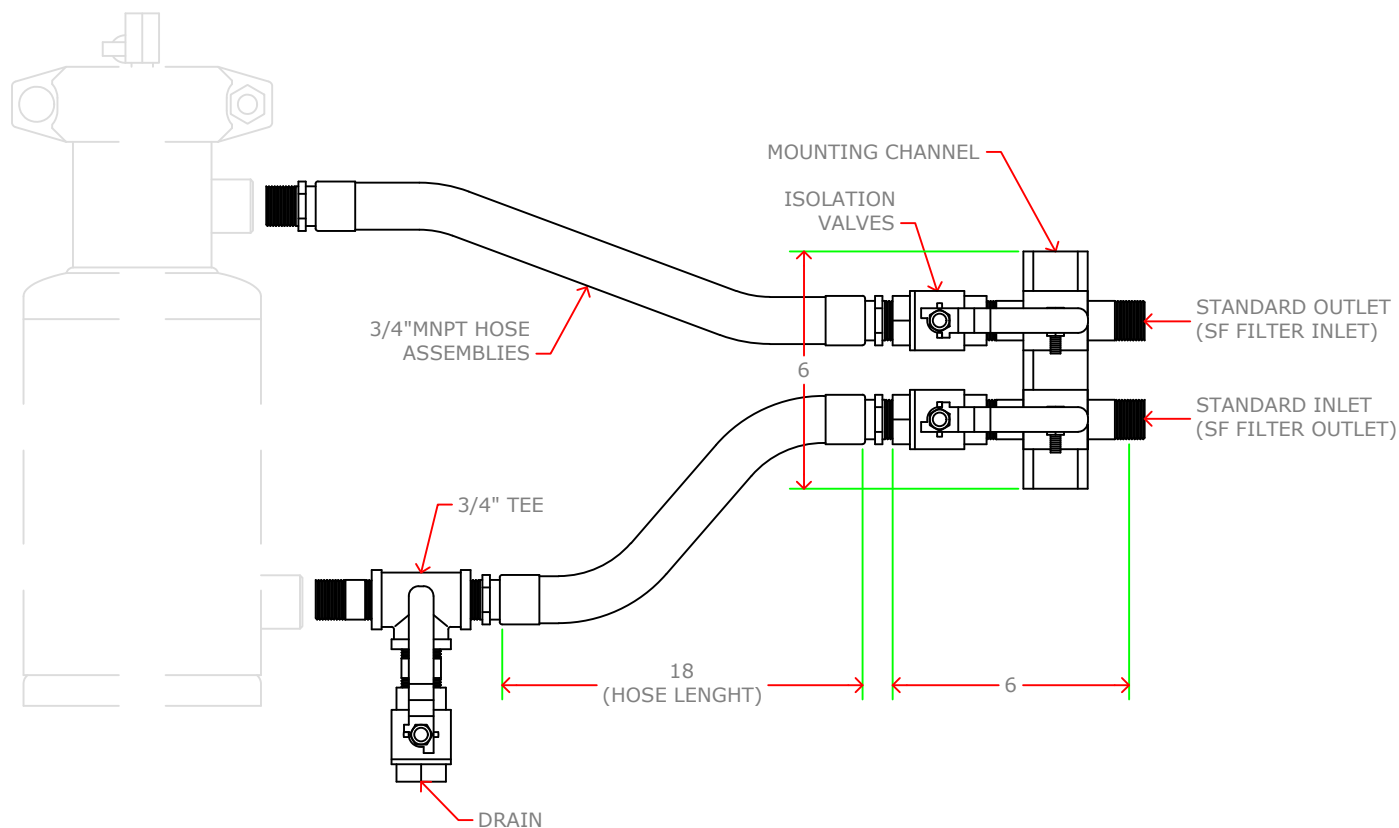

Capacity: N/A Gallons

Max Temp.: 200 F

Max Press.: 200 PSI

Weight: 20 Lbs.

20	x	x
19	x	x
18	x	x
17	x	x
16	x	x
15	x	x
14	x	x
13	x	x
12	x	x
11	x	x
10	x	x
9	x	x
8	x	x
7	x	x
6	x	x
5	x	x
4	x	x
3	x	x
2	x	x
1	x	x

#	PART	DESCRIPTION
F	x	xx/xx/xx
E	x	xx/xx/xx
D	x	xx/xx/xx
C	x	xx/xx/xx
B	x	xx/xx/xx

REV DESCRIPTION DATE

General Treatment Products, Inc.
 PO Box 8697, Brea, CA 92822
 Phone: 714) 257-9165 <http://www.gtpcompany.com>
 Fax: 714) 257-9215 customerservice@gtpcompany.com

Date: 1/1/12 Scale: NTS Rev.: A

Description:
 "EASY FIT" FLAT BOTTOM VALVE PACKAGE

Model:
 EFFB



MATERIALS OF CONSTRUCTION:
 CARBON STEEL, BRASS, STAINLESS STEEL,
 BUTYL RUBBER HOSE

Capacity: N/A Gallons

Max Temp.: 200 F

Max Press.: 200 PSI

Weight: 20 Lbs.

20	x	x
19	x	x
18	x	x
17	x	x
16	x	x
15	x	x
14	x	x
13	x	x
12	x	x
11	x	x
10	x	x
9	x	x
8	x	x
7	x	x
6	x	x
5	x	x
4	x	x
3	x	x
2	x	x
1	x	x

#	PART	DESCRIPTION
F	x	xx/xx/xx
E	x	xx/xx/xx
D	x	xx/xx/xx
C	x	xx/xx/xx
B	x	xx/xx/xx

REV	DESCRIPTION	DATE
-----	-------------	------

General Treatment Products, Inc.
 PO Box 8697, Brea, CA 92822
 Phone: 714) 257-9165 <http://www.gtpcompany.com>
 Fax: 714) 257-9215 customerservice@gtpcompany.com

Date: 1/1/12 Scale: NTS Rev.: A

Description:
 "EAST FIT" DOME BOTTOM VALVE PACKAGE

Model:
 EFDB

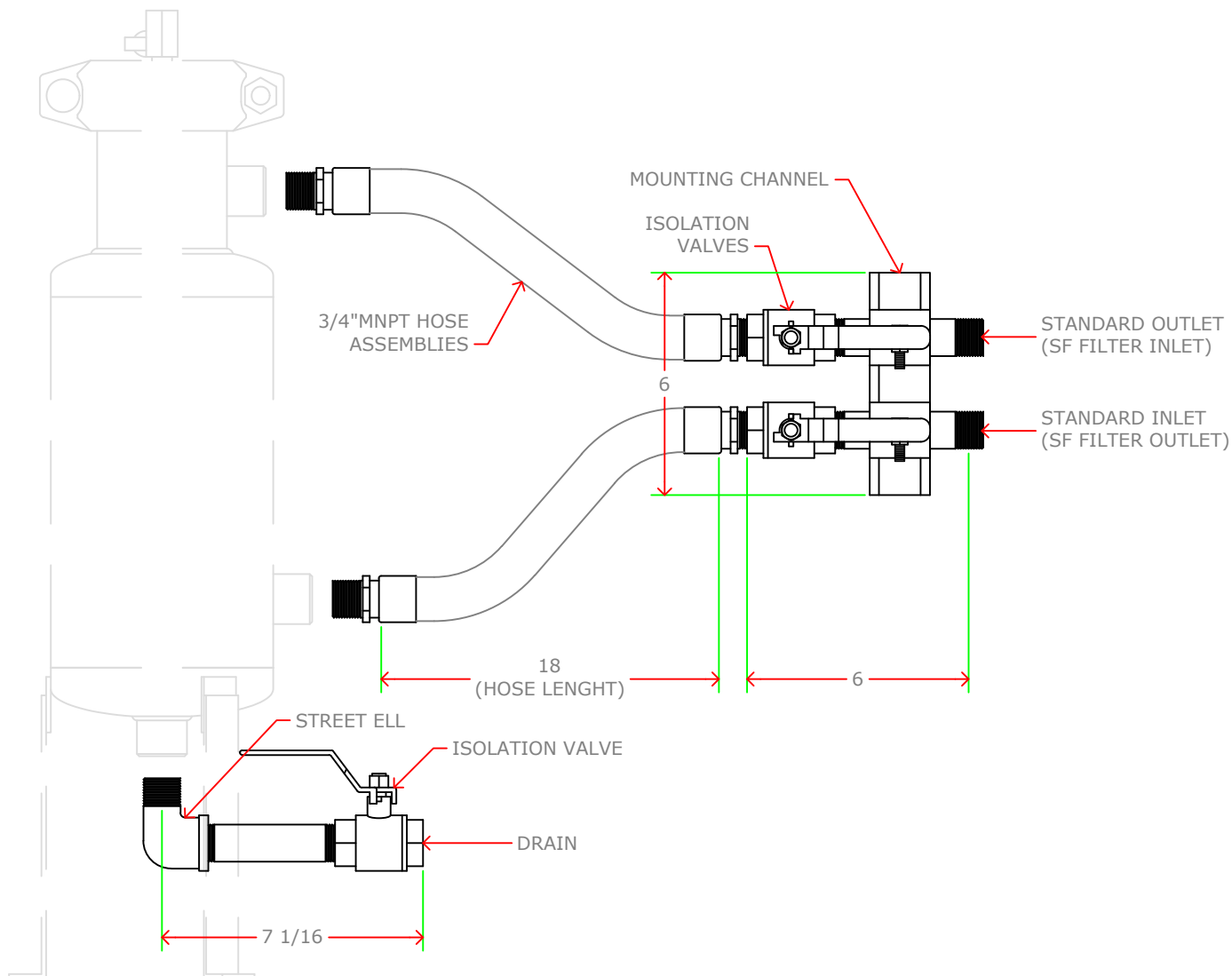

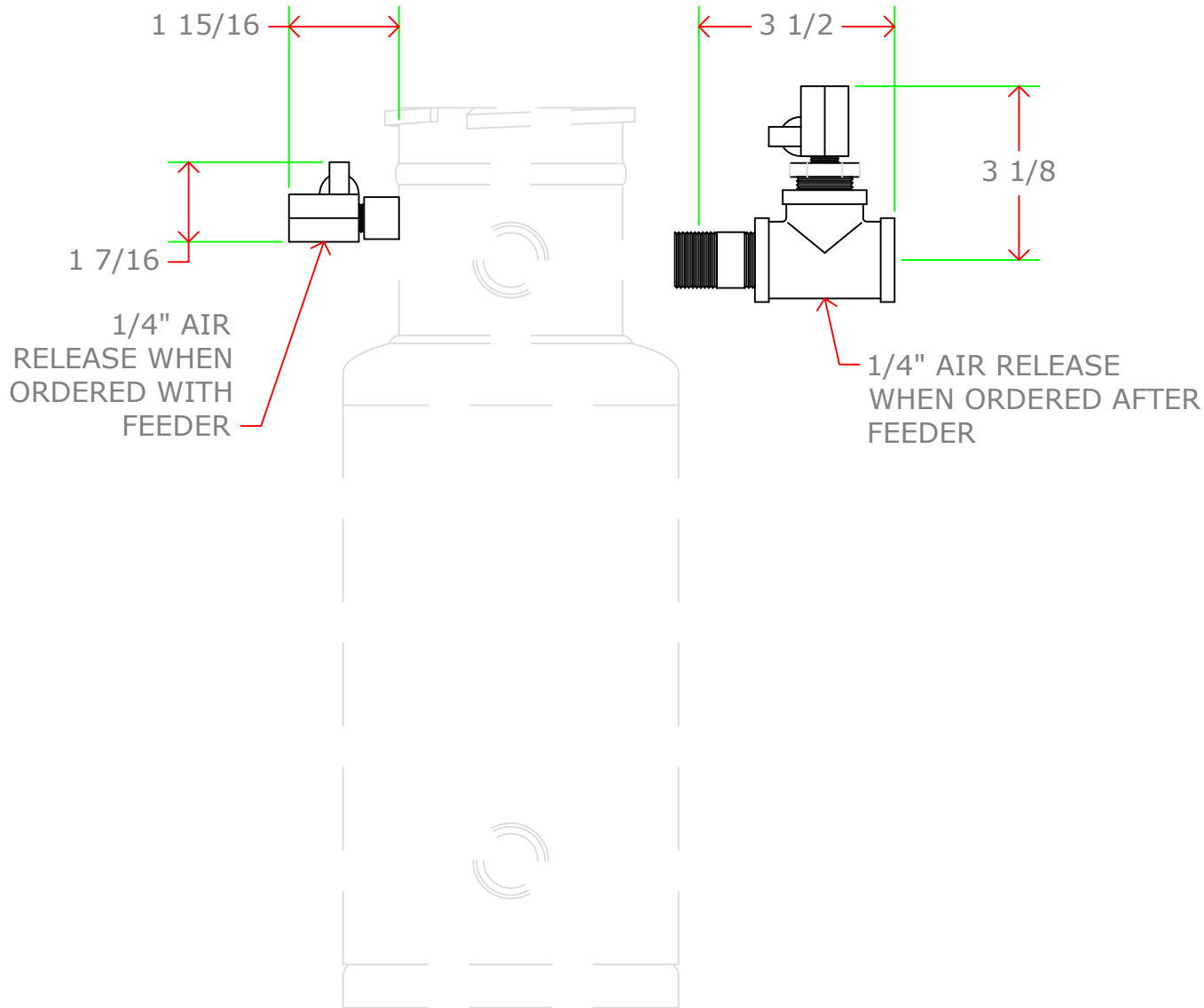
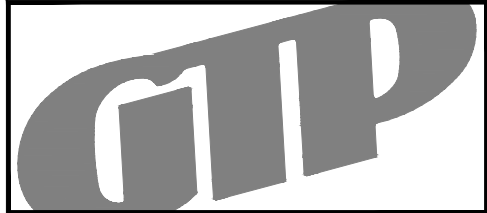

MATERIALS OF CONSTRUCTION:
CARBON STEEL, BRASS

Capacity: N/A Gallons
Max Temp.: 200 F
Max Press.: 300 PSI
Weight: 3 Lbs.

20	x	x
19	x	x
18	x	x
17	x	x
16	x	x
15	x	x
14	x	x
13	x	x
12	x	x
11	x	x
10	x	x
9	x	x
8	x	x
7	x	x
6	x	x
5	x	x
4	x	x
3	x	x
2	x	x
1	x	x

#	PART	DESCRIPTION
F	x	xx/xx/xx
E	x	xx/xx/xx
D	x	xx/xx/xx
C	x	xx/xx/xx
B	x	xx/xx/xx
REV	DESCRIPTION	DATE

General Treatment Products, Inc.
 PO Box 8697, Brea, CA 92822
 Phone: 714) 257-9165 <http://www.gtpcompany.com>
 Fax: 714) 257-9215 customerservice@gtpcompany.com

Date: 1/1/12 Scale: NTS Rev.: A

Description:
AIR RELEASE VALVE ASSEMBLY

Model:
AR

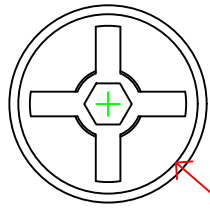

PRE-2016
PF20 (OLD STYLE)

2 $\frac{3}{4}$ "

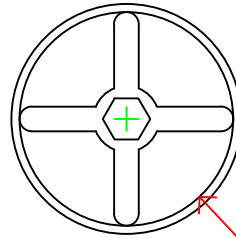

PF20 &
PF20/QC

3 $\frac{1}{4}$ "

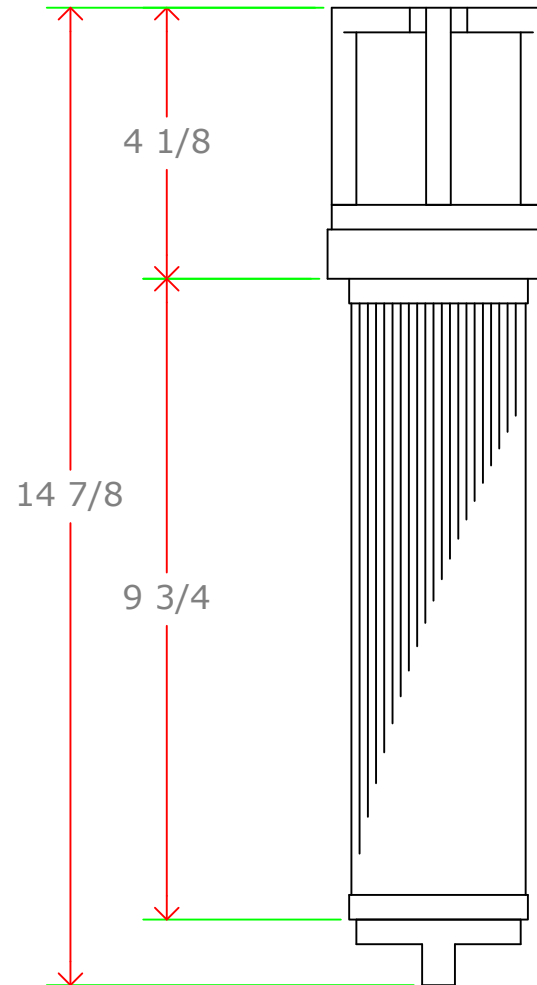
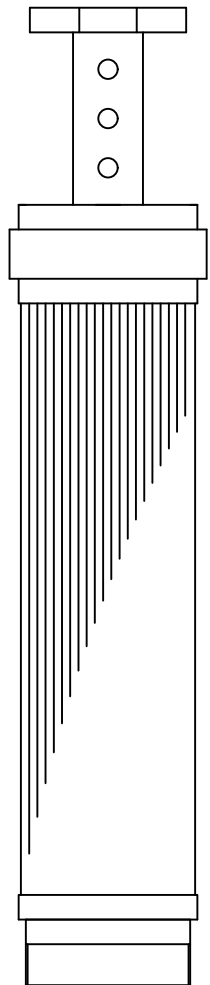

4 $\frac{1}{8}$

14 $\frac{7}{8}$

9 $\frac{3}{4}$

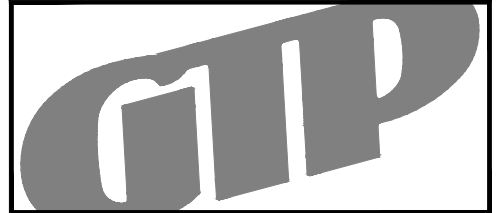

MATERIALS OF CONSTRUCTION:
RYTON, BUNA, POLYPROPYLENE,
STAINLESS STEEL

Capacity: N/A Gallons

Max Temp.: 180 F

Max Press.: N/A PSI

Weight: 2 Lbs.

20	x	x
19	x	x
18	x	x
17	x	x
16	x	x
15	x	x
14	x	x
13	x	x
12	x	x
11	x	x
10	x	x
9	x	x
8	x	x
7	x	x
6	x	x
5	x	x
4	x	x
3	x	x
2	x	x
1	x	x

#	PART	DESCRIPTION
F	x	xx/xx/xx
E	x	xx/xx/xx
D	x	xx/xx/xx
C	x	xx/xx/xx
B	x	xx/xx/xx
REV	DESCRIPTION	DATE

General Treatment Products, Inc.
PO Box 8697, Brea, CA 92822
Phone: 714) 257-9165 <http://www.gtpcompany.com>
Fax: 714) 257-9215 customerservice@gtpcompany.com

Date: 9/1/2015 Scale: NTS Rev.: A

Description:
20MICRON PLEATED FILTER ASSEMBLY

Model:
PF20 & PF20/QC

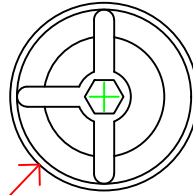
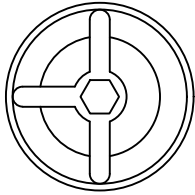

3 1/2" D

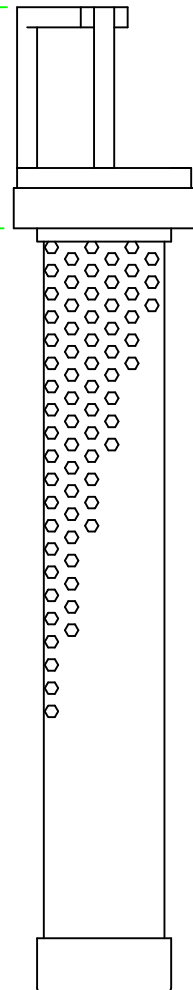
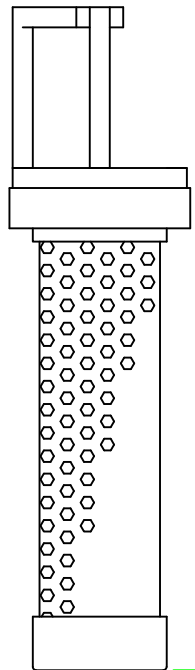

4 1/8

8 1/4

14 1/4

1 GALLON
MODEL ONLY

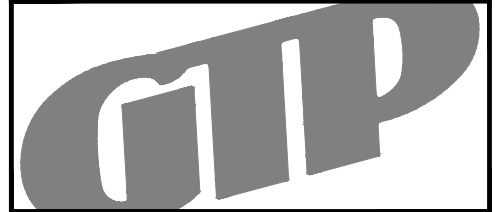

MATERIALS OF CONSTRUCTION:
POLYESTER FELT, CARBON STEEL RING,
RYTON, STAINLESS STEEL

Capacity: N/A Gallons
Max Temp.: 180 F
Max Press.: N/A PSI
Weight: 2 Lbs.
Voltage.: x VAC x Phs x Hz
FLA.: x amps

20	x	x
19	x	x
18	x	x
17	x	x
16	x	x
15	x	x
14	x	x
13	x	x
12	x	x
11	x	x
10	x	x
9	x	x
8	x	x
7	x	x
6	x	x
5	x	x
4	x	x
3	x	x
2	x	x
1	x	x

#	PART	DESCRIPTION
F	x	xx/xx/xx
E	x	xx/xx/xx
D	x	xx/xx/xx
C	x	xx/xx/xx
B	x	xx/xx/xx

REV DESCRIPTION DATE

General Treatment Products, Inc.
PO Box 8697, Brea, CA 92822
Phone: 714) 257-9165 <http://www.gtpcompany.com>
Fax: 714) 257-9215 customerservice@gtpcompany.com

Date: 1/1/12 Scale: NTS Rev.: A

Description:
SOCK FILTER AND HANDLE ASSEMBLY

Model:
SF25



MATERIALS OF CONSTRUCTION:
CARBON STEEL, BRASS, DUCTILE IRON

Capacity: N/A Gallons

Max Temp.: 200 F

Max Press.: 300 PSI

Weight: 12 Lbs.

20	x	x
19	x	x
18	x	x
17	x	x
16	x	x
15	x	x
14	x	x
13	x	x
12	x	x
11	x	x
10	x	x
9	x	x
8	x	x
7	x	x
6	x	x
5	x	x
4	x	x
3	x	x
2	x	x
1	x	x

#	PART	DESCRIPTION
F	x	xx/xx/xx
E	x	xx/xx/xx
D	x	xx/xx/xx
C	x	xx/xx/xx
B	x	xx/xx/xx

REV	DESCRIPTION	DATE
-----	-------------	------

General Treatment Products, Inc.
PO Box 8697, Brea, CA 92822
Phone: 714) 257-9165 <http://www.gtpcompany.com>
Fax: 714) 257-9215 customerservice@gtpcompany.com

Date: 1/1/12 Scale: NTS Rev.: A

Description:
FILL FUNNEL AND VALVE ASSEMBLY

Model:
FL06V & FL10V

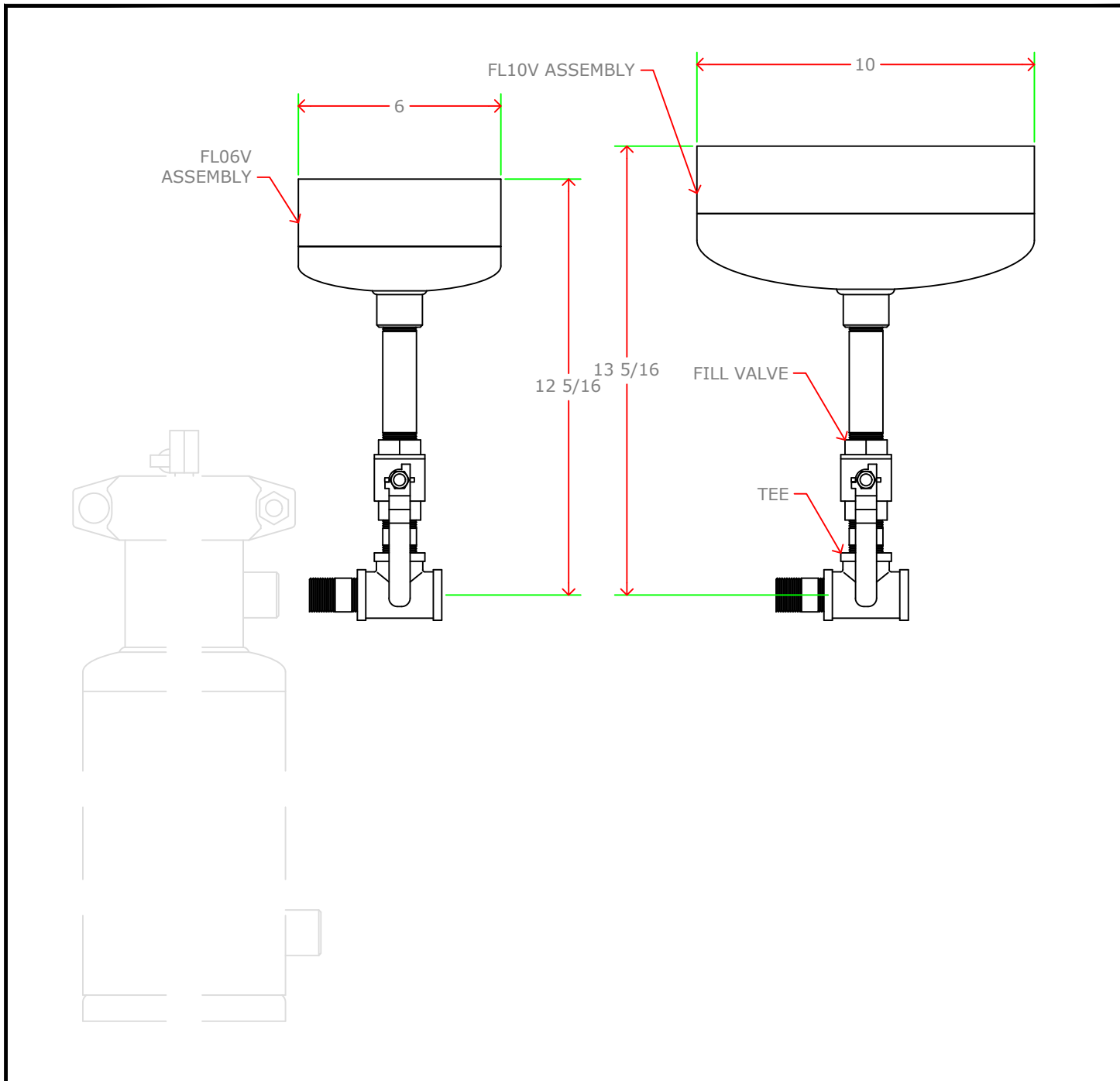

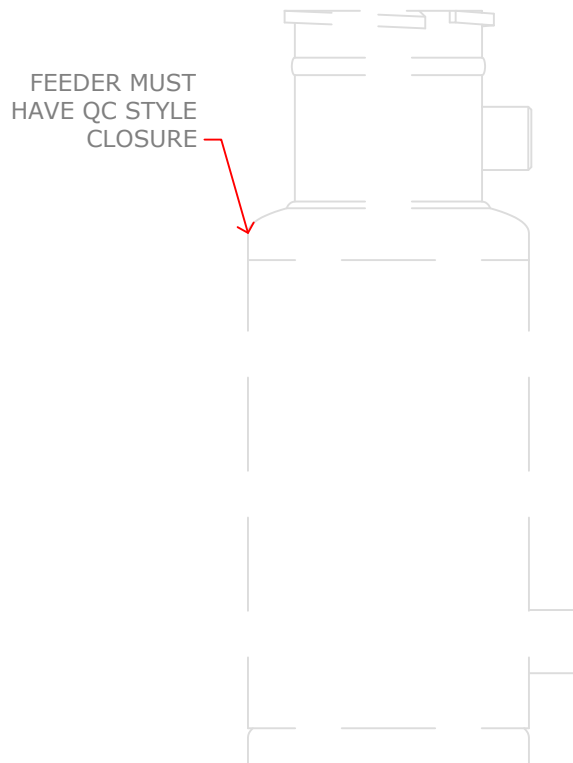
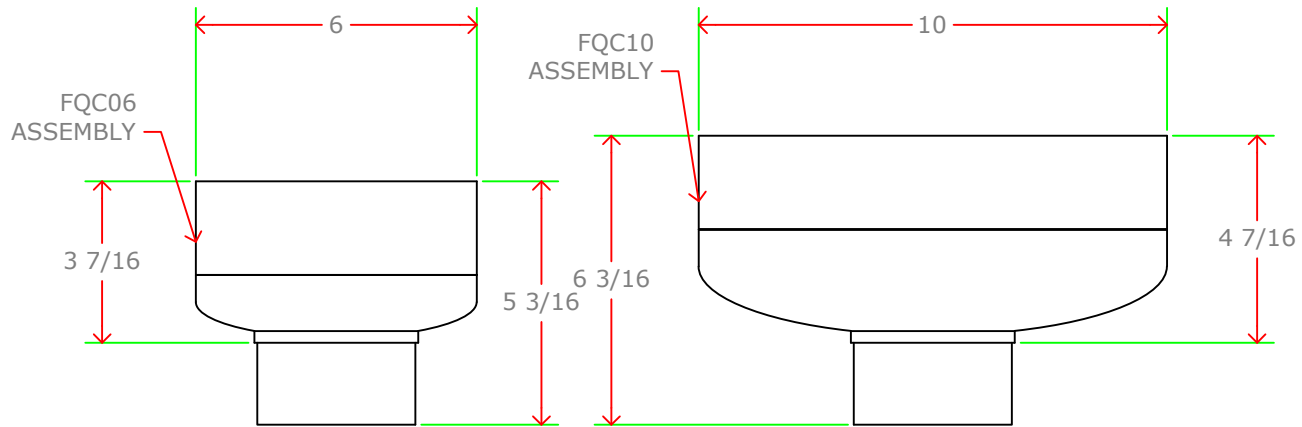
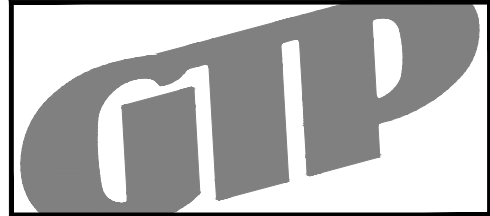

MATERIALS OF CONSTRUCTION:
CARBON STEEL

Capacity: N/A Gallons
Max Temp.: 200 F
Max Press.: N/A PSI
Weight: 10 Lbs.

20	x	x
19	x	x
18	x	x
17	x	x
16	x	x
15	x	x
14	x	x
13	x	x
12	x	x
11	x	x
10	x	x
9	x	x
8	x	x
7	x	x
6	x	x
5	x	x
4	x	x
3	x	x
2	x	x
1	x	x

#	PART	DESCRIPTION
F	x	xx/xx/xx
E	x	xx/xx/xx
D	x	xx/xx/xx
C	x	xx/xx/xx
B	x	xx/xx/xx

REV	DESCRIPTION	DATE
-----	-------------	------

General Treatment Products, Inc.
 PO Box 8697, Brea, CA 92822
 Phone: 714) 257-9165 <http://www.gtpcompany.com>
 Fax: 714) 257-9215 customerservice@gtpcompany.com

Date: 1/1/12 Scale: NTS Rev.: A

Description:
"QC" STYLE FILL FUNNEL

Model:
FQC06 & FQC10

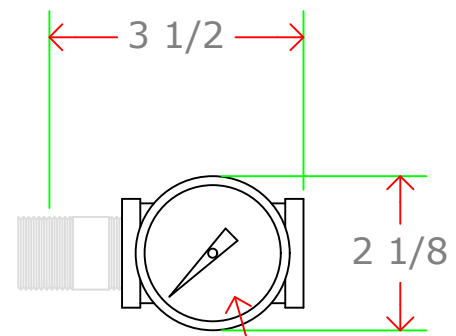
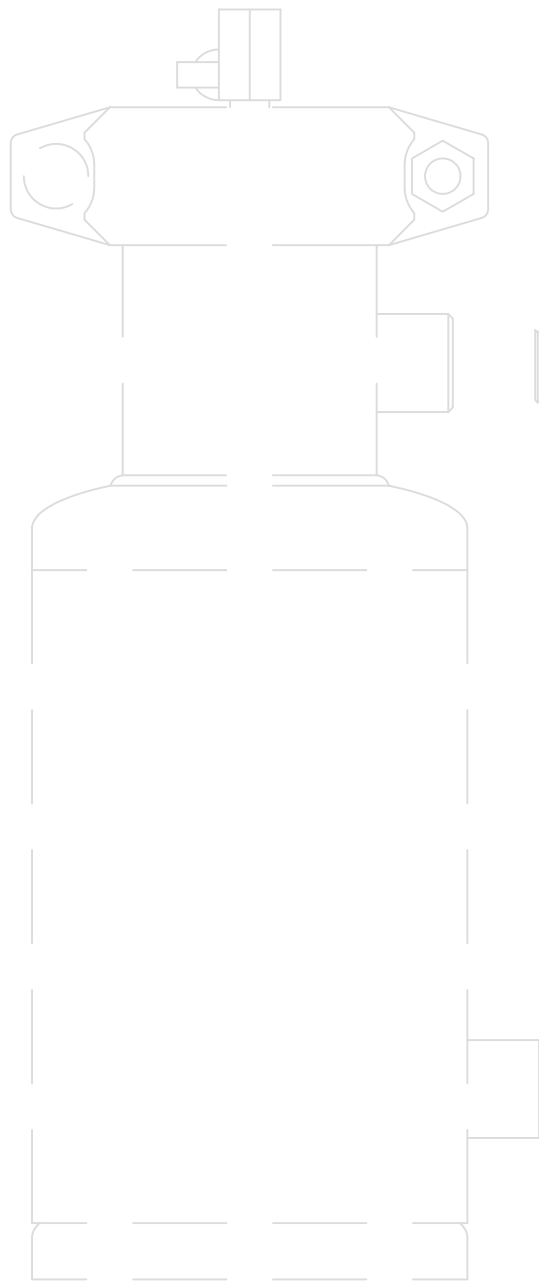

0-300PSI
GAUGE AND
INSTALLATION
TEE



MATERIALS OF CONSTRUCTION:
CARBON STEEL, BRASS, STAINLESS STEEL

Capacity:	N/A	Gallons				
Max Temp.:	200	F				
Max Press.:	300	PSI				
Weight:	1	Lbs.				
Voltage.:	x	VAC	x	Phs	x	Hz
FLA.:	x	amps				

20	x	x
19	x	x
18	x	x
17	x	x
16	x	x
15	x	x
14	x	x
13	x	x
12	x	x
11	x	x
10	x	x
9	x	x
8	x	x
7	x	x
6	x	x
5	x	x
4	x	x
3	x	x
2	x	x
1	x	x

#	PART	DESCRIPTION
F	x	xx/xx/xx
E	x	xx/xx/xx
D	x	xx/xx/xx
C	x	xx/xx/xx
B	x	xx/xx/xx

REV	DESCRIPTION	DATE
-----	-------------	------

General Treatment Products, Inc.
 PO Box 8697, Brea, CA 92822
 Phone: 714) 257-9165 <http://www.gtpcompany.com>
 Fax: 714) 257-9215 customerservice@gtpcompany.com

Date: 1/1/12 Scale: NTS Rev.: A

Description:
300PSI PRESSURE GAUGE AND TEE

Model:
PG300

NOTICE: This drawing and its contents are for the specific use of GTP customers only. It is not to be duplicated or copied without expressed written consent of General Treatment Products, Inc. We reserve the right to modify this drawing without notice.



MATERIALS OF CONSTRUCTION:
BRASS, TEMPERED GLASS, EPDM

Capacity: N/A Gallons
Max Temp.: 350 F
Max Press.: 125 PSI
Weight: 2 Lbs.

20	x	x
19	x	x
18	x	x
17	x	x
16	x	x
15	x	x
14	x	x
13	x	x
12	x	x
11	x	x
10	x	x
9	x	x
8	x	x
7	x	x
6	x	x
5	x	x
4	x	x
3	x	x
2	x	x
1	x	x

#	PART	DESCRIPTION
F	x	xx/xx/xx
E	x	xx/xx/xx
D	x	xx/xx/xx
C	x	xx/xx/xx
B	x	xx/xx/xx

REV	DESCRIPTION	DATE
-----	-------------	------

General Treatment Products, Inc.
 PO Box 8697, Brea, CA 92822
 Phone: 714) 257-9165 <http://www.gtpcompany.com>
 Fax: 714) 257-9215 customerservice@gtpcompany.com

Date: 1/1/12 Scale: NTS Rev.: A

Description:
SIGHT LEVEL INDICATOR

Model:
S125

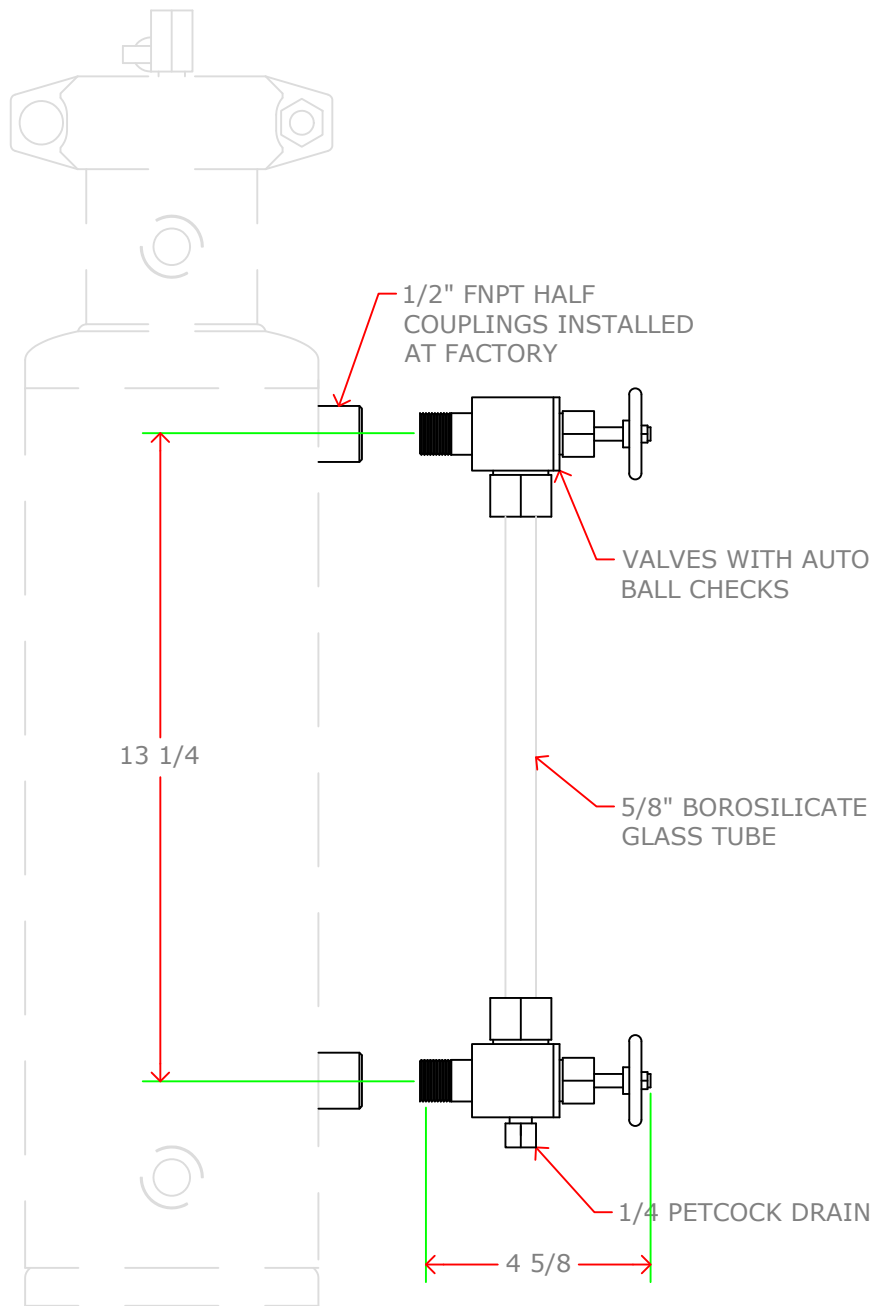

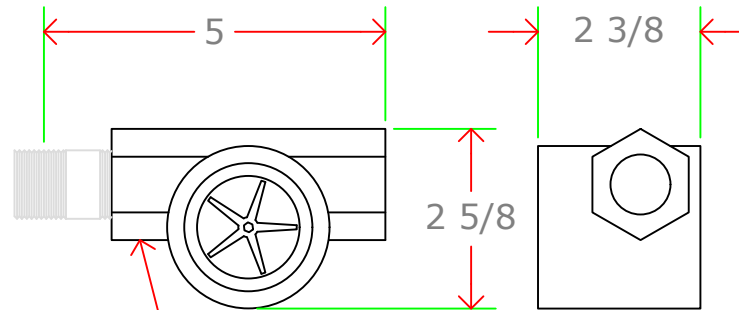
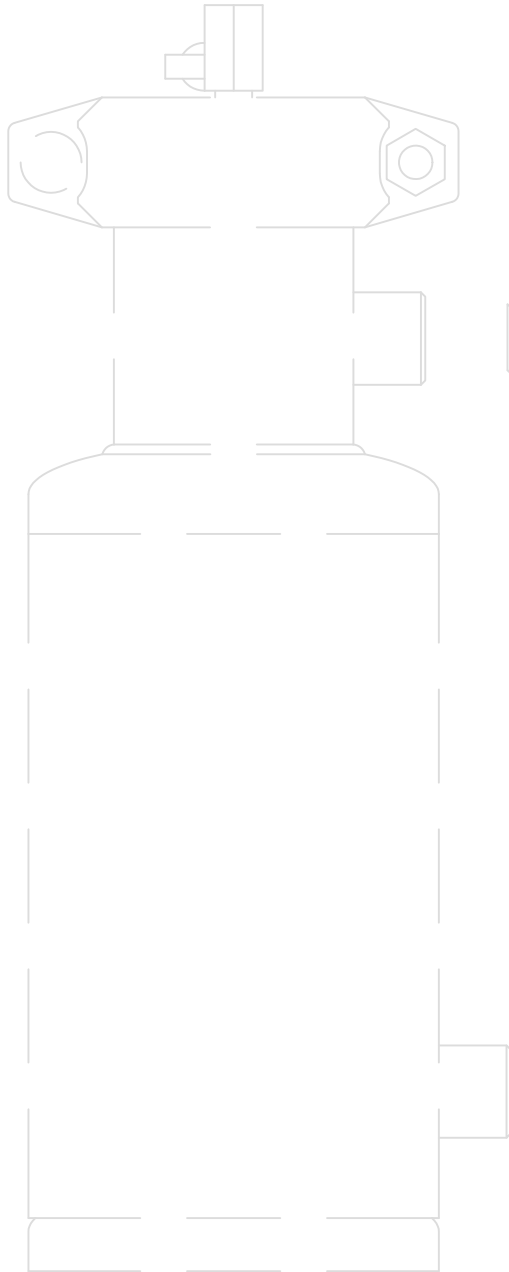

BRASS SIGHT FLOW INDICATOR

NOTE: SIGHT FLOW INDICATOR SHOULD BE INSTALLED ON OUTLET SIDE OF FEEDER. MOVE TO LOWER SIDE FITTING FOR SOCK FILTER APPLICATIONS.

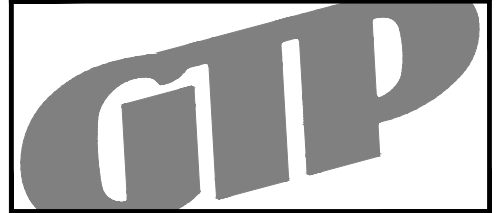

MATERIALS OF CONSTRUCTION:
BRASS, CARBON STEEL, TEMPERED GLASS,
BUNA-N, ABS, STAINLESS STEEL

Capacity:	N/A	Gallons				
Max Temp.:	200	F				
Max Press.:	125	PSI				
Weight:	8	Lbs.				
Voltage.:	x	VAC	x	Phs	x	Hz
FLA.:	x	amps				

20	x	x
19	x	x
18	x	x
17	x	x
16	x	x
15	x	x
14	x	x
13	x	x
12	x	x
11	x	x
10	x	x
9	x	x
8	x	x
7	x	x
6	x	x
5	x	x
4	x	x
3	x	x
2	x	x
1	x	x

#	PART	DESCRIPTION
F	x	xx/xx/xx
E	x	xx/xx/xx
D	x	xx/xx/xx
C	x	xx/xx/xx
B	x	xx/xx/xx

REV	DESCRIPTION	DATE
-----	-------------	------

General Treatment Products, Inc.
PO Box 8697, Brea, CA 92822
Phone: 714) 257-9165 <http://www.gtpcompany.com>
Fax: 714) 257-9215 customerservice@gtpcompany.com

Date: 1/1/12 Scale: NTS Rev.: A

Description:
SIGHT FLOW INDICATOR

Model:
SFI-075-125



MATERIALS OF CONSTRUCTION:
CARBON STEEL

Capacity: N/A Gallons

Max Temp.: N/A F

Max Press.: N/A PSI

Weight: 20 Lbs.

20	x	x
19	x	x
18	x	x
17	x	x
16	x	x
15	x	x
14	x	x
13	x	x
12	x	x
11	x	x
10	x	x
9	x	x
8	x	x
7	x	x
6	x	x
5	x	x
4	x	x
3	x	x
2	x	x
1	x	x

#	PART	DESCRIPTION
F	x	xx/xx/xx
E	x	xx/xx/xx
D	x	xx/xx/xx
C	x	xx/xx/xx
B	x	xx/xx/xx

REV	DESCRIPTION	DATE
-----	-------------	------

General Treatment Products, Inc.
PO Box 8697, Brea, CA 92822
Phone: 714) 257-9165 <http://www.gtpcompany.com>
Fax: 714) 257-9215 customerservice@gtpcompany.com

Date: 1/1/12 **Scale:** NTS **Rev.:** A

Description:
WALL MOUNTING STRAPS, 6" & 10"

Model:
STRPxx

SHOWN WITH
MODEL: FB5

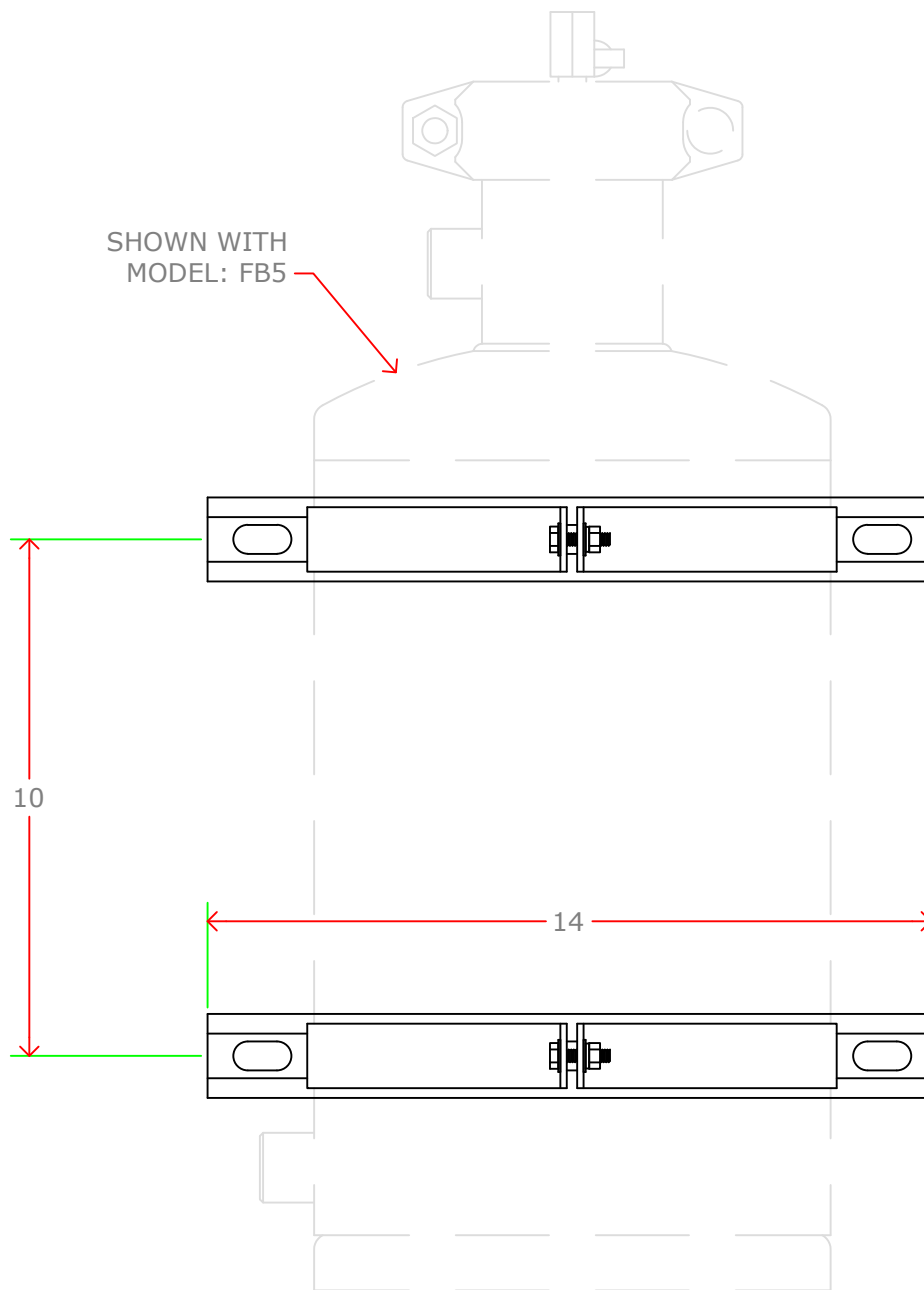

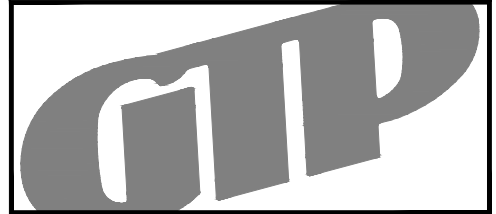

MATERIALS OF CONSTRUCTION:
CARBON STEEL

Capacity: N/A Gallons
Max Temp.: N/A F
Max Press.: N/A PSI
Weight: 2 Lbs.

20	x	x
19	x	x
18	x	x
17	x	x
16	x	x
15	x	x
14	x	x
13	x	x
12	x	x
11	x	x
10	x	x
9	x	x
8	x	x
7	x	x
6	x	x
5	x	x
4	x	x
3	x	x
2	x	x
1	x	x

#	PART	DESCRIPTION
F	x	xx/xx/xx
E	x	xx/xx/xx
D	x	xx/xx/xx
C	x	xx/xx/xx
B	x	xx/xx/xx
REV	DESCRIPTION	DATE

General Treatment Products, Inc.
 PO Box 8697, Brea, CA 92822
 Phone: 714) 257-9165 <http://www.gtpcompany.com>
 Fax: 714) 257-9215 customerservice@gtpcompany.com

Date: 1/1/16 **Scale:** NTS **Rev.:** A

Description:
FEEDER BODY TABS

Model:
TABS

