

MATERIALS OF CONSTRUCTION:
 ENAMEL PAINTED CARBON STEEL, BRASS,
 316 STAINLESS STEEL

x	x	x	x	x	x	x	x	x
x	x	x	x	x	x	x	x	x
x	x	x	x	x	x	x	x	x
GD-B-0750	5.9"	9.4"	11.3"	40"	5.2"	4.5"	2.3"	x
GD-B-0500	5.9"	8.8"	10.7"	36"	4.7"	4"	2.3"	x
GD-B-0330	5.9"	8.5"	10.5"	36"	4.3"	4"	2.3"	x
GD-B-0250	5.9"	7.5"	9"	36"	3.7"	4"	2.3"	x
GD-B-0166	5.9"	7.5"	9"	32"	3.7"	3.5"	2.3"	x

MODEL A B C D E F G H
 DIMENSIONS:

Max Temp.:	105	F
Weight/FLA: 1/8HP	24 Lbs.	4 amps
Weight/FLA: 1/4HP	28 Lbs.	6 amps
Weight/FLA: 1/3HP	30 Lbs.	7 amps
Weight/FLA: 1/2HP	35 Lbs.	8 amps
Weight/FLA: 3/4HP	43 Lbs.	11 amps
Voltage.:	115 VAC	1 Phs 60 Hz

10	x	x
9	x	x
8	x	x
7	x	x
6	x	x
5	x	x
4	x	x
3	x	x
2	x	x
1	x	x

#	PART	DESCRIPTION
F	x	xx/xx/xx
E	x	xx/xx/xx
D	x	xx/xx/xx
C	x	xx/xx/xx
B	x	xx/xx/xx
REV	DESCRIPTION	DATE

General Treatment Products, Inc.
 PO Box 8697, Brea, CA 92822
 Phone: 714) 257-9165
 Fax: 714) 257-9215
<http://www.gtpcompany.com>
customerservice@gtpcompany.com

Date: 09/01/13 Scale: NTS Rev.: A

Description:
GD BRACKET MOUNT MIXER

Model:
GD-B-xxxx

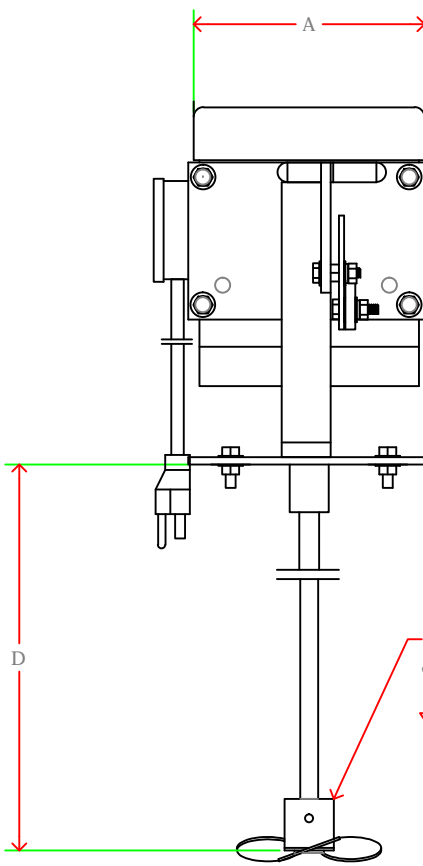
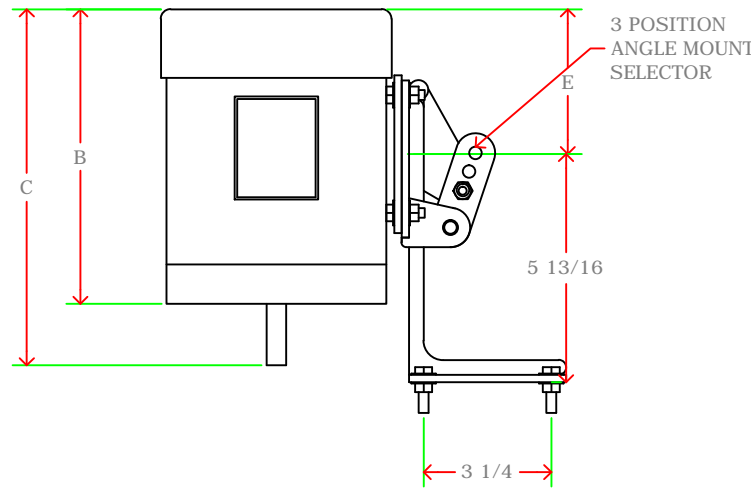
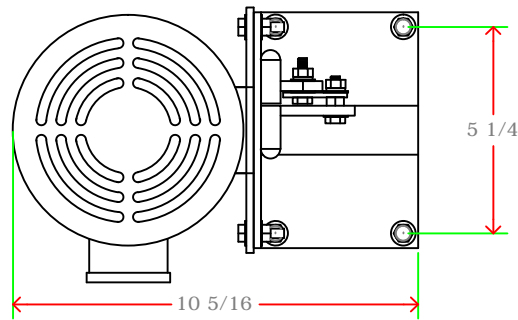

"E" STAMPED PROPELLER
 "N" NEOPRENE IMPELLER
 "P" CAST PROPELLER

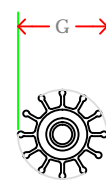
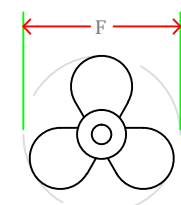
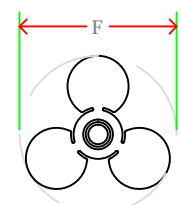

NOTICE: This drawing and it's contents are for the specific use of GTP customers only. It is not to be duplicated or copied without expressed written concent or General Treatment Products, Inc. We reserve the right to modify this drawing without notice.

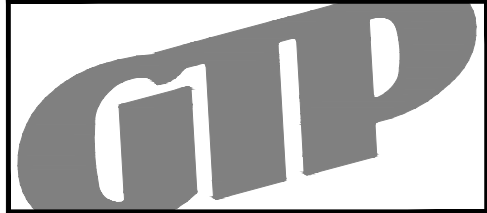

MATERIALS OF CONSTRUCTION:
 ENAMEL PAINTED CARBON STEEL, BRASS,
 316 STAINLESS STEEL

x	x	x	x	x	x	x	x	x
x	x	x	x	x	x	x	x	x
x	x	x	x	x	x	x	x	x
GD-C-0750	5.9"	9.4"	11.3"	40"	5.2"	4.5"	2.3"	x
GD-C-0500	5.9"	8.8"	10.7"	36"	4.7"	4"	2.3"	x
GD-C-0330	5.9"	8.5"	10.5"	36"	4.3"	4"	2.3"	x
GD-C-0250	5.9"	7.5"	9"	36"	3.7"	4"	2.3"	x
GD-C-0166	5.9"	7.5"	9"	32"	3.7"	3.5"	2.3"	x

MODEL A B C D E F G H
 DIMENSIONS:

Max Temp.:	105	F
Weight/FLA: 1/8HP	24 Lbs.	4 amps
Weight/FLA: 1/4HP	28 Lbs.	6 amps
Weight/FLA: 1/3HP	30 Lbs.	7 amps
Weight/FLA: 1/2HP	35 Lbs.	8 amps
Weight/FLA: 3/4HP	43 Lbs.	11 amps
Voltage.:	115 VAC	1 Phs 60 Hz

10	x	x
9	x	x
8	x	x
7	x	x
6	x	x
5	x	x
4	x	x
3	x	x
2	x	x
1	x	x

#	PART	DESCRIPTION
F	x	xx/xx/xx
E	x	xx/xx/xx
D	x	xx/xx/xx
C	x	xx/xx/xx
B	x	xx/xx/xx
REV	DESCRIPTION	DATE

General Treatment Products, Inc.
 PO Box 8697, Brea, CA 92822
 Phone: 714) 257-9165
 Fax: 714) 257-9215
<http://www.gtpcompany.com>
customerservice@gtpcompany.com

Date: 09/01/13 Scale: NTS Rev.: A

Description:
GD CLAMP MOUNT ASSEMBLY

Model:
GD-C-xxxx

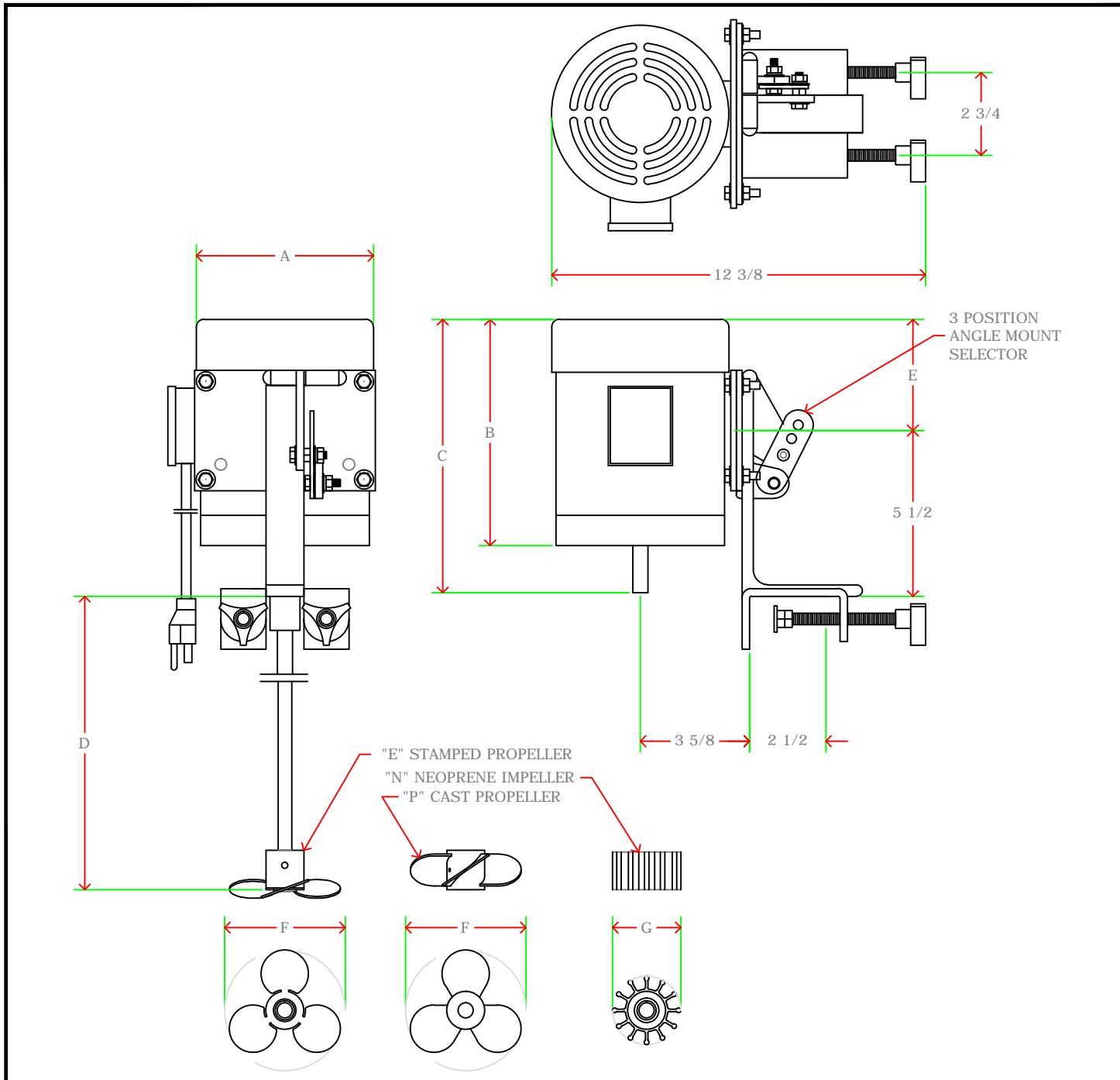

NOTICE: This drawing and its contents are for the specific use of GTP customers only. It is not to be duplicated or copied without expressed written consent of General Treatment Products, Inc. We reserve the right to modify this drawing without notice.



MATERIALS OF CONSTRUCTION:
 ENAMEL PAINTED CARBON STEEL, BRASS,
 316 STAINLESS STEEL

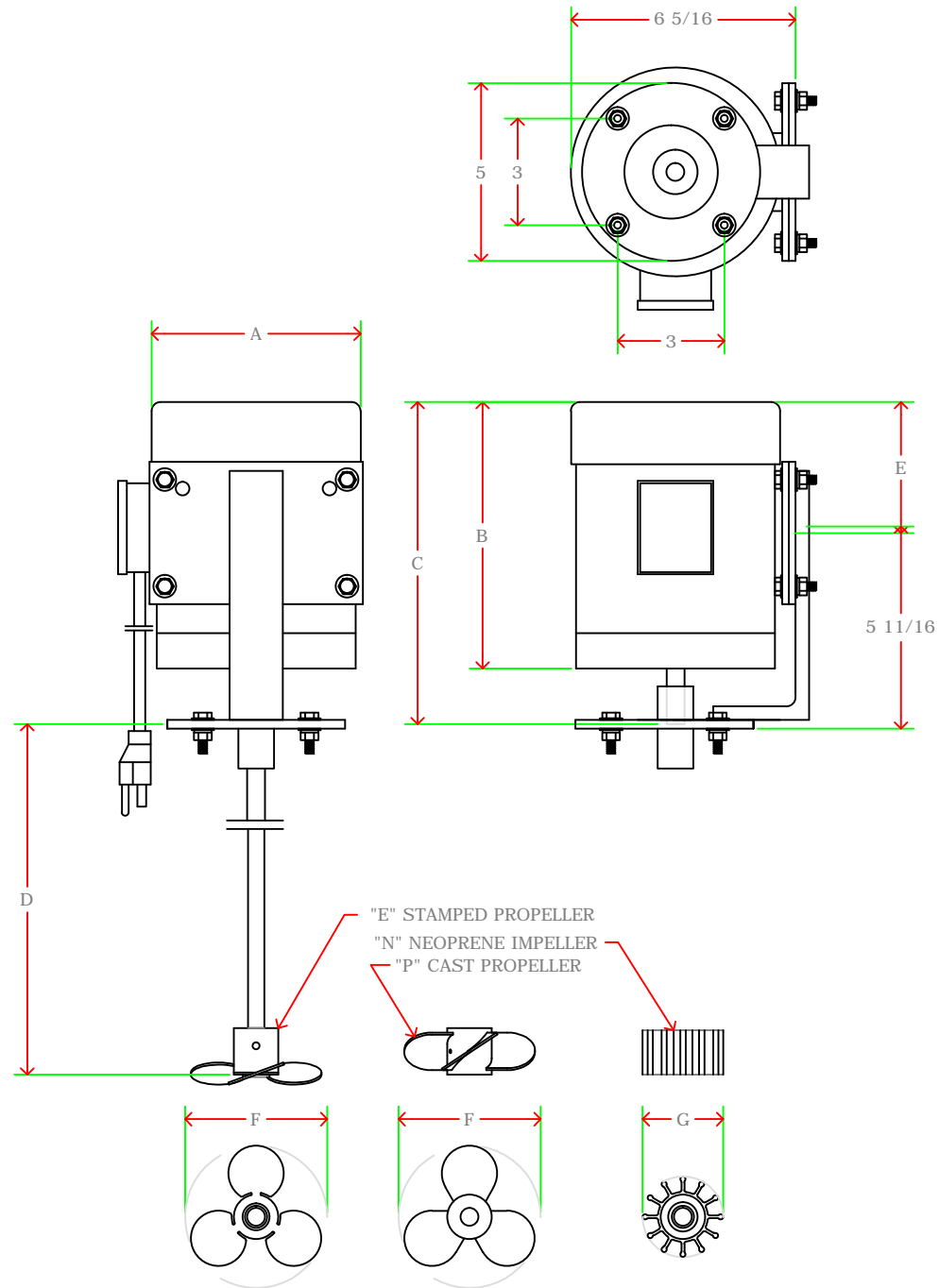

x	x	x	x	x	x	x	x	x
x	x	x	x	x	x	x	x	x
x	x	x	x	x	x	x	x	x
GD-F-0750	5.9"	9.4"	11.3"	40"	5.2"	4.5"	2.3"	x
GD-F-0500	5.9"	8.8"	10.7"	36"	4.7"	4"	2.3"	x
GD-F-0330	5.9"	8.5"	10.5"	36"	4.3"	4"	2.3"	x
GD-F-0250	5.9"	7.5"	9"	36"	3.7"	4"	2.3"	x
GD-F-0166	5.9"	7.5"	9"	32"	3.7"	3.5"	2.3"	x

MODEL A B C D E F G H
 DIMENSIONS:

Max Temp.: 105 F

Weight/FLA: 1/8HP	24 Lbs.	4 amps
Weight/FLA: 1/4HP	28 Lbs.	6 amps
Weight/FLA: 1/3HP	30 Lbs.	7 amps
Weight/FLA: 1/2HP	35 Lbs.	8 amps
Weight/FLA: 3/4HP	43 Lbs.	11 amps

Voltage.: 115 VAC 1 Phs 60 Hz

10	x	x
9	x	x
8	x	x
7	x	x
6	x	x
5	x	x
4	x	x
3	x	x
2	x	x
1	x	x

#	PART	DESCRIPTION
F	x	xx/xx/xx
E	x	xx/xx/xx
D	x	xx/xx/xx
C	x	xx/xx/xx
B	x	xx/xx/xx
REV	DESCRIPTION	DATE

General Treatment Products, Inc.
 PO Box 8697, Brea, CA 92822
 Phone: 714) 257-9165 <http://www.gtpcompany.com>
 Fax: 714) 257-9215 customerservice@gtpcompany.com

Date: 09/01/13 Scale: NTS Rev.: A

Description:
GD FLANGE MOUNT MIXER

Model:
GD-F-xxxx

NOTICE: This drawing and it's contents are for the specific use of GTP customers only. It is not to be duplicated or copied without expressed written concent or General Treatment Products, Inc. We reserve the right to modify this drawing without notice.

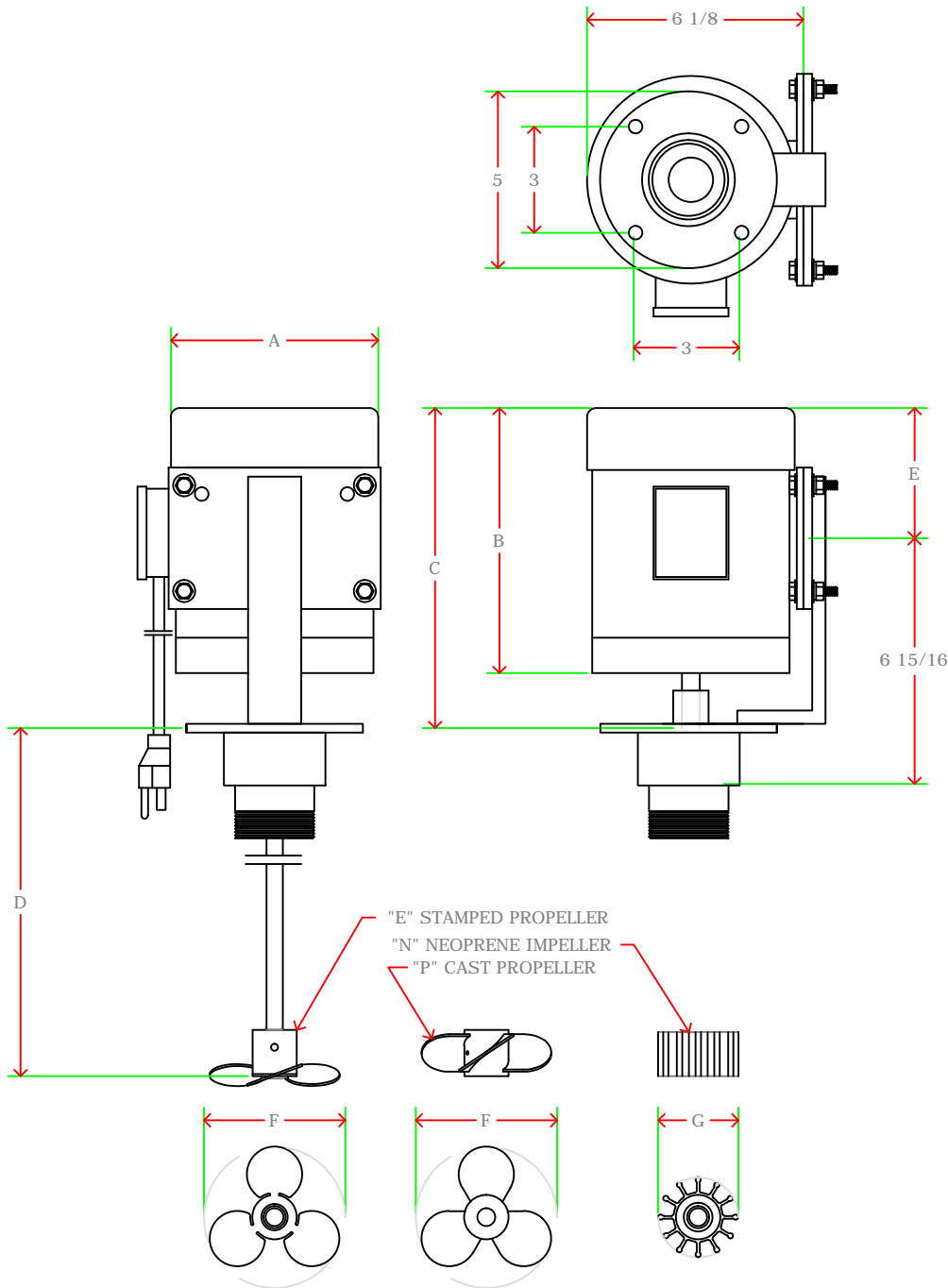
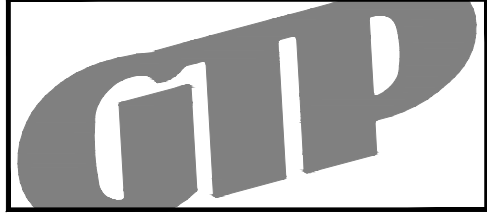

MATERIALS OF CONSTRUCTION:
 ENAMEL PAINTED CARBON STEEL, BRASS,
 316 STAINLESS STEEL

x	x	x	x	x	x	x	x	x
x	x	x	x	x	x	x	x	x
x	x	x	x	x	x	x	x	x
GD-T-0750	5.9"	9.4"	11.3"	40"	5.2"	4.5"	2.3"	x
GD-T-0500	5.9"	8.8"	10.7"	36"	4.7"	4"	2.3"	x
GD-T-0330	5.9"	8.5"	10.5"	36"	4.3"	4"	2.3"	x
GD-T-0250	5.9"	7.5"	9"	36"	3.7"	4"	2.3"	x
GD-T-0166	5.9"	7.5"	9"	32"	3.7"	3.5"	2.3"	x

MODEL A B C D E F G H
 DIMENSIONS:

Max Temp.:	105	F
Weight/FLA: 1/8HP	24	Lbs. 4 amps
Weight/FLA: 1/4HP	28	Lbs. 6 amps
Weight/FLA: 1/3HP	30	Lbs. 7 amps
Weight/FLA: 1/2HP	35	Lbs. 8 amps
Weight/FLA: 3/4HP	43	Lbs. 11 amps
Voltage.:	115	VAC 1 Phs 60 Hz

10	x	x
9	x	x
8	x	x
7	x	x
6	x	x
5	x	x
4	x	x
3	x	x
2	x	x
1	x	x

#	PART	DESCRIPTION
F	x	xx/xx/xx
E	x	xx/xx/xx
D	x	xx/xx/xx
C	x	xx/xx/xx
B	x	xx/xx/xx
REV	DESCRIPTION	DATE

General Treatment Products, Inc.
 PO Box 8697, Brea, CA 92822
 Phone: 714) 257-9165
 Fax: 714) 257-9215
<http://www.gtpcompany.com>
customerservice@gtpcompany.com

Date: 09/01/13 Scale: NTS Rev.: A

Description:
GD THREAD MOUNT MIXER

Model:
GD-T-xxxx

NOTICE: This drawing and it's contents are for the specific use of GTP customers only. It is not to be duplicated or copied without expressed written concent or General Treatment Products, Inc. We reserve the right to modify this drawing without notice.

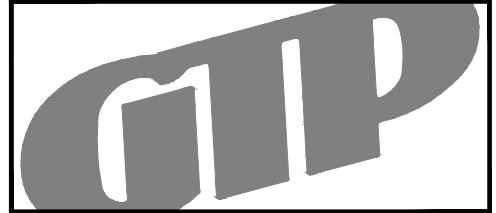

MATERIALS OF CONSTRUCTION:
 ENAMEL PAINTED CARBON STEEL, BRASS,
 316 STAINLESS STEEL

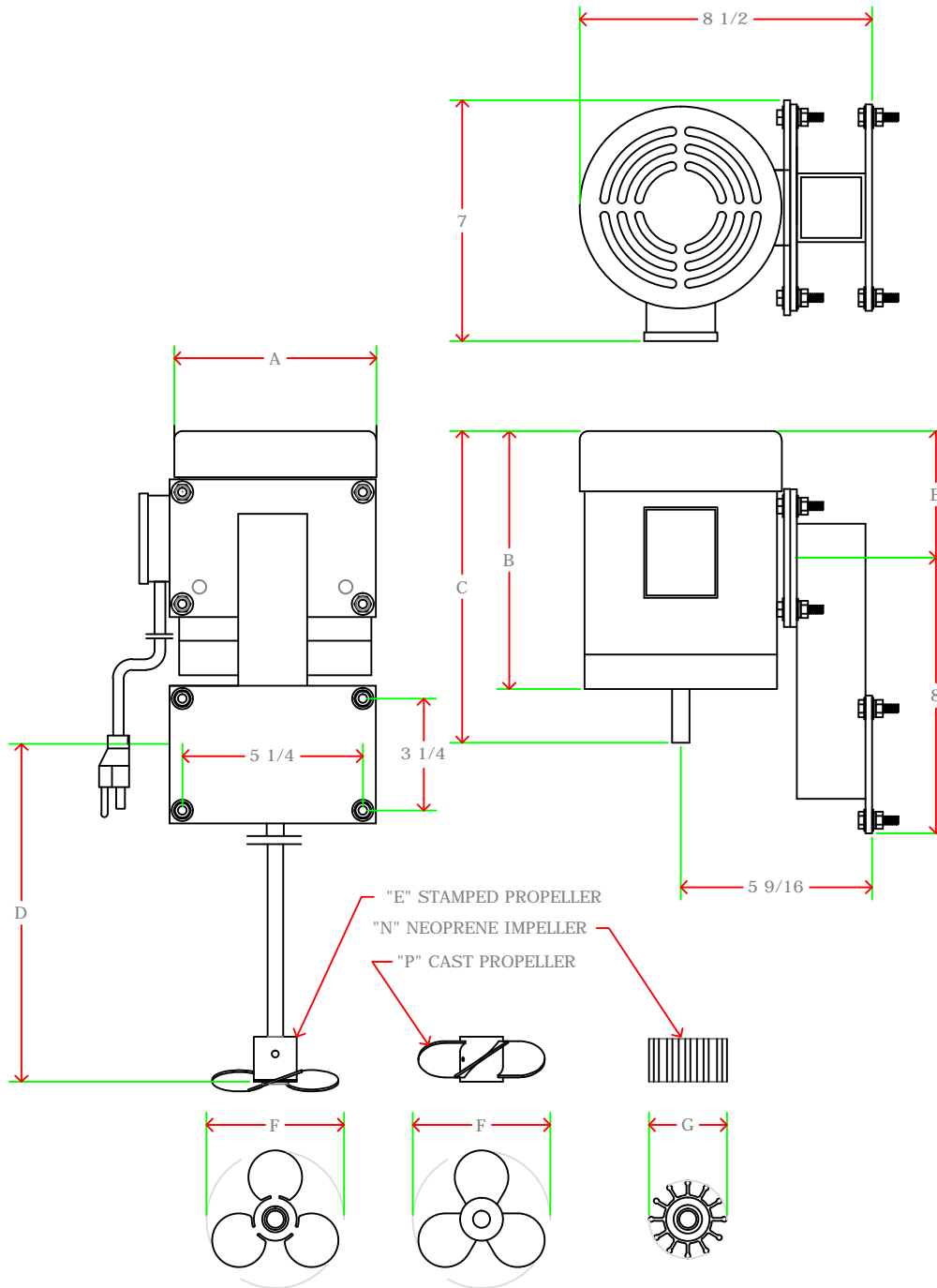

x	x	x	x	x	x	x	x	x
x	x	x	x	x	x	x	x	x
x	x	x	x	x	x	x	x	x
GD-X-0750	5.9"	9.4"	11.3"	40"	5.2"	4.5"	2.3"	x
GD-X-0500	5.9"	8.8"	10.7"	36"	4.7"	4"	2.3"	x
GD-X-0330	5.9"	8.5"	10.5"	36"	4.3"	4"	2.3"	x
GD-X-0250	5.9"	7.5"	9"	36"	3.7"	4"	2.3"	x
GD-X-0166	5.9"	7.5"	9"	32"	3.7"	3.5"	2.3"	x
MODEL	A	B	C	D	E	F	G	H

DIMENSIONS:

Max Temp.: 105 F

Weight/FLA: 1/8HP 24 Lbs. 4 amps

Weight/FLA: 1/4HP 28 Lbs. 6 amps

Weight/FLA: 1/3HP 30 Lbs. 7 amps

Weight/FLA: 1/2HP 35 Lbs. 8 amps

Weight/FLA: 3/4HP 43 Lbs. 11 amps

Voltage.: 115 VAC 1 Phs 60 Hz

10	x	x
9	x	x
8	x	x
7	x	x
6	x	x
5	x	x
4	x	x
3	x	x
2	x	x
1	x	x

#	PART	DESCRIPTION
F	x	xx/xx/xx
E	x	xx/xx/xx
D	x	xx/xx/xx
C	x	xx/xx/xx
B	x	xx/xx/xx
REV	DESCRIPTION	DATE

General Treatment Products, Inc.
 PO Box 8697, Brea, CA 92822
 Phone: 714) 257-9165 <http://www.gtpcompany.com>
 Fax: 714) 257-9215 customerservice@gtpcompany.com

Date: 09/01/13 Scale: NTS Rev.: A

Description:
GD TANK STAND MOUNT MIXER

Model:
GD-X-xxxx

NOTICE: This drawing and it's contents are for the specific use of GTP customers only. It is not to be duplicated or copied without expressed written concent or General Treatment Products, Inc. We reserve the right to modify this drawing without notice.