

MATERIALS OF CONSTRUCTION:  
CARBON STEEL

Capacity:	x	Gallons				
Max Temp.:	200	F				
Max Press.:	150	PSI				
Weight:	106	Lbs.				
Voltage.:	x	VAC	x	Phs	x	Hz
FLA.:	x	amps				

20	x	x
19	x	x
18	x	x
17	x	x
16	x	x
15	x	x
14	x	x
13	x	x
12	x	x
11	x	x
10	x	x
9	x	x
8	x	x
7	x	x
6	x	x
5	x	x
4	x	x
3	x	x
2	x	x
1	x	x

#	PART	DESCRIPTION
F	x	xx/xx/xx
E	x	xx/xx/xx
D	x	xx/xx/xx
C	x	xx/xx/xx
B	x	xx/xx/xx
REV	DESCRIPTION	DATE

General Treatment Products, Inc.  
PO Box 8697, Brea, CA 92822  
Phone: 714) 257-9165 <http://www.gtpcompany.com>  
Fax: 714) 257-9215 [customerservice@gtpcompany.com](mailto:customerservice@gtpcompany.com)

Date: 1/1/14 Scale: NTS Rev.: A

Description:  
**3/8" 4-9 GPM THREADED SEPARATOR**

Model:  
**STX-0038**

NOTICE: This drawing and its contents are for the specific use of GTP customers only. It is not to be duplicated or copied without expressed written consent of General Treatment Products, Inc. We reserve the right to modify this drawing without notice.

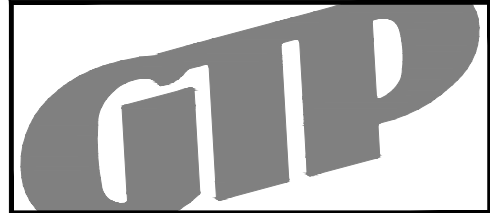
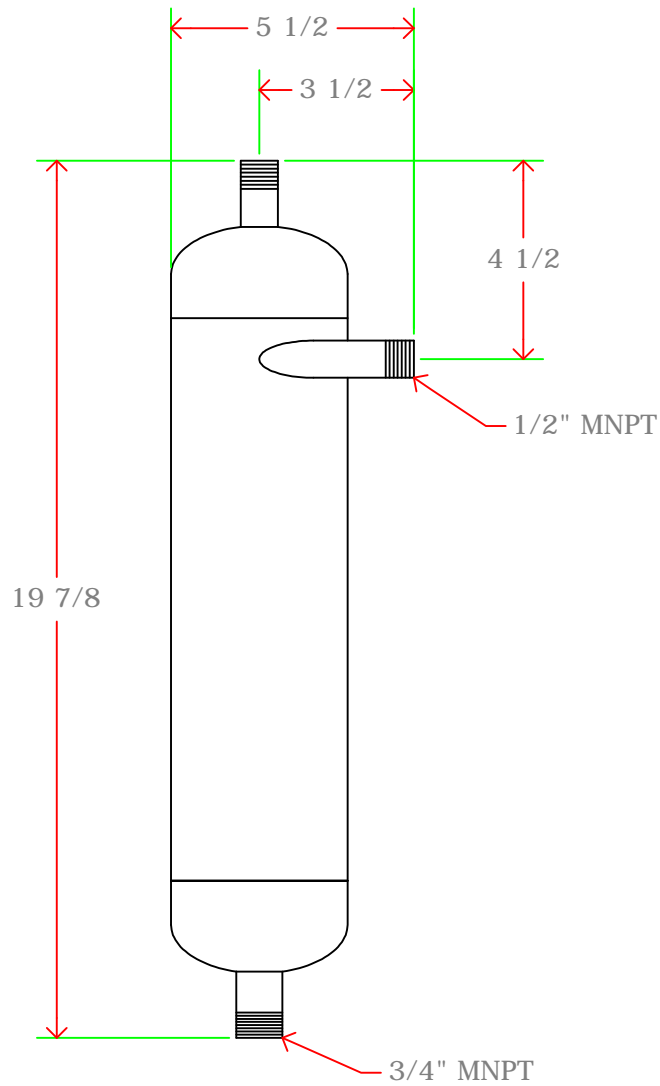
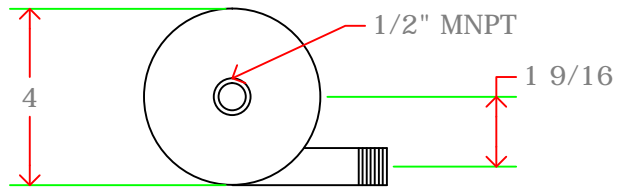

MATERIALS OF CONSTRUCTION:  
CARBON STEEL

Capacity:	x	Gallons				
Max Temp.:	200	F				
Max Press.:	150	PSI				
Weight:	113	Lbs.				
Voltage.:	x	VAC	x	Phs	x	Hz
FLA.:	x	amps				

20	x	x
19	x	x
18	x	x
17	x	x
16	x	x
15	x	x
14	x	x
13	x	x
12	x	x
11	x	x
10	x	x
9	x	x
8	x	x
7	x	x
6	x	x
5	x	x
4	x	x
3	x	x
2	x	x
1	x	x

#	PART	DESCRIPTION
F	x	xx/xx/xx
E	x	xx/xx/xx
D	x	xx/xx/xx
C	x	xx/xx/xx
B	x	xx/xx/xx
REV	DESCRIPTION	DATE

General Treatment Products, Inc.  
PO Box 8697, Brea, CA 92822  
Phone: 714) 257-9165 <http://www.gtpcompany.com>  
Fax: 714) 257-9215 [customerservice@gtpcompany.com](mailto:customerservice@gtpcompany.com)

Date: 1/1/14 Scale: NTS Rev.: A

Description:  
1/2" 6-12 GPM THREADED SEPARATOR

Model:  
STX-0050

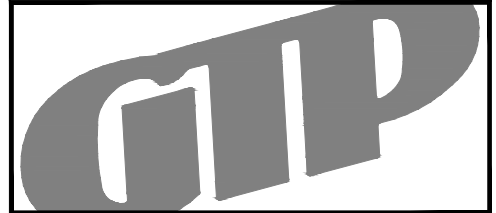
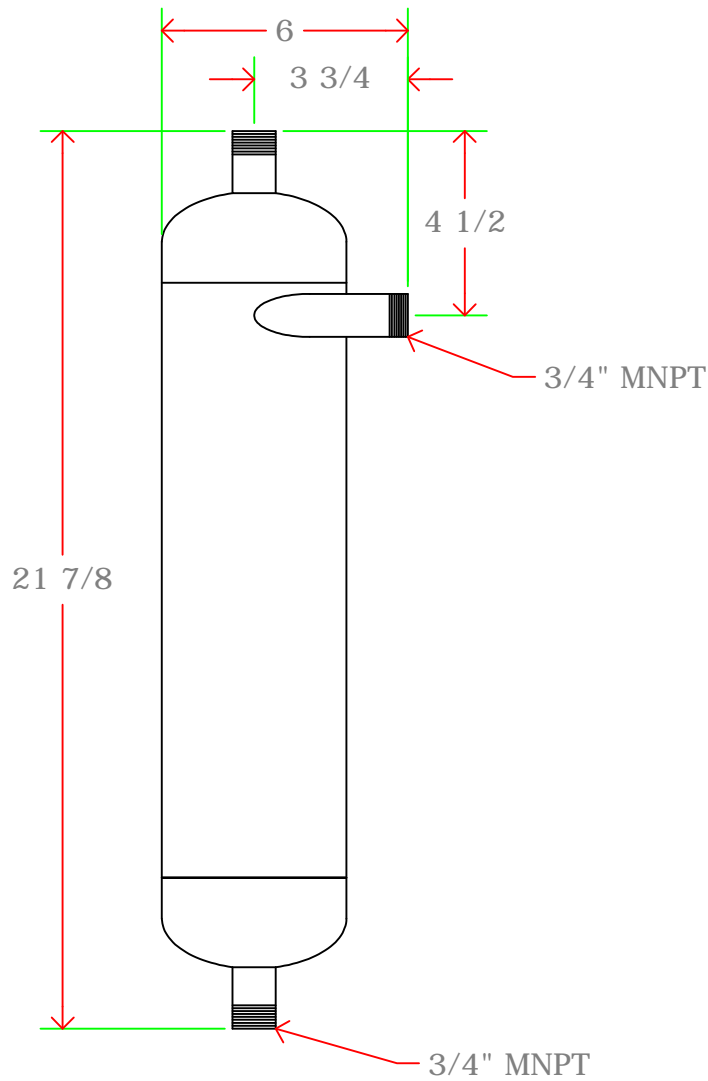
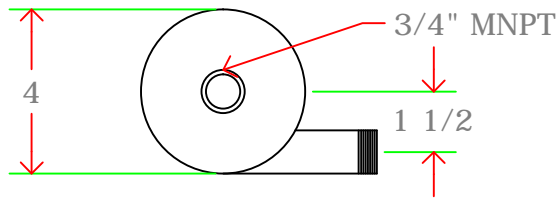

MATERIALS OF CONSTRUCTION:  
CARBON STEEL

Capacity:	x	Gallons				
Max Temp.:	200	F				
Max Press.:	150	PSI				
Weight:	124	Lbs.				
Voltage.:	x	VAC	x	Phs	x	Hz
FLA.:	x	amps				

20	x	x
19	x	x
18	x	x
17	x	x
16	x	x
15	x	x
14	x	x
13	x	x
12	x	x
11	x	x
10	x	x
9	x	x
8	x	x
7	x	x
6	x	x
5	x	x
4	x	x
3	x	x
2	x	x
1	x	x

#	PART	DESCRIPTION
F	x	xx/xx/xx
E	x	xx/xx/xx
D	x	xx/xx/xx
C	x	xx/xx/xx
B	x	xx/xx/xx
REV	DESCRIPTION	DATE

General Treatment Products, Inc.  
PO Box 8697, Brea, CA 92822  
Phone: 714) 257-9165 <http://www.gtpcompany.com>  
Fax: 714) 257-9215 [customerservice@gtpcompany.com](mailto:customerservice@gtpcompany.com)

Date: 1/1/14 Scale: NTS Rev.: A

Description:  
3/4" 12-23 GPM THREADED SEPARATOR

Model:  
STX-0075

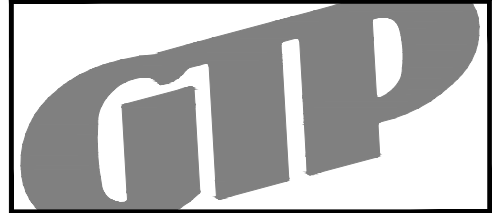
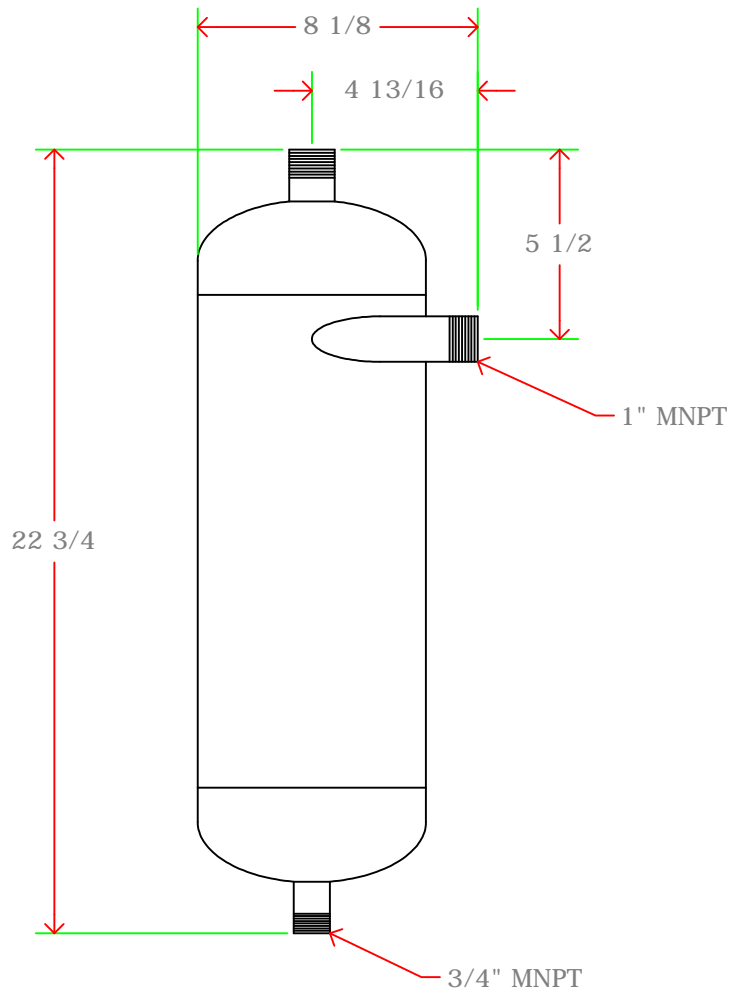
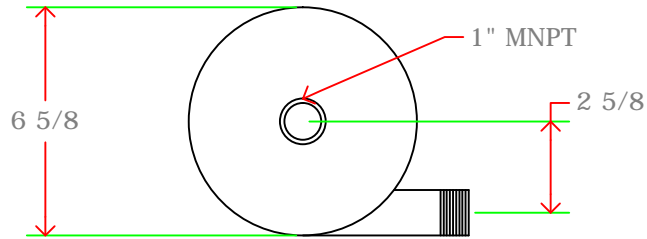

MATERIALS OF CONSTRUCTION:  
CARBON STEEL

Capacity:	x	Gallons				
Max Temp.:	200	F				
Max Press.:	150	PSI				
Weight:	130	Lbs.				
Voltage.:	x	VAC	x	Phs	x	Hz
FLA.:	x	amps				

20	x	x
19	x	x
18	x	x
17	x	x
16	x	x
15	x	x
14	x	x
13	x	x
12	x	x
11	x	x
10	x	x
9	x	x
8	x	x
7	x	x
6	x	x
5	x	x
4	x	x
3	x	x
2	x	x
1	x	x

#	PART	DESCRIPTION
F	x	xx/xx/xx
E	x	xx/xx/xx
D	x	xx/xx/xx
C	x	xx/xx/xx
B	x	xx/xx/xx
REV	DESCRIPTION	DATE

General Treatment Products, Inc.  
 PO Box 8697, Brea, CA 92822  
 Phone: 714) 257-9165 <http://www.gtpcompany.com>  
 Fax: 714) 257-9215 [customerservice@gtpcompany.com](mailto:customerservice@gtpcompany.com)

Date: 1/1/14 Scale: NTS Rev.: A

Description:  
1" 22-38 GPM THREADED SEPARATOR

Model:  
STX-0100

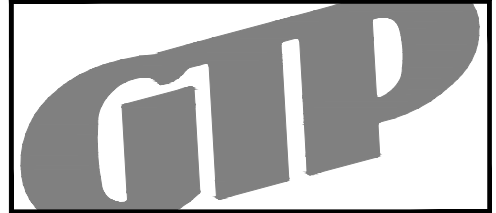
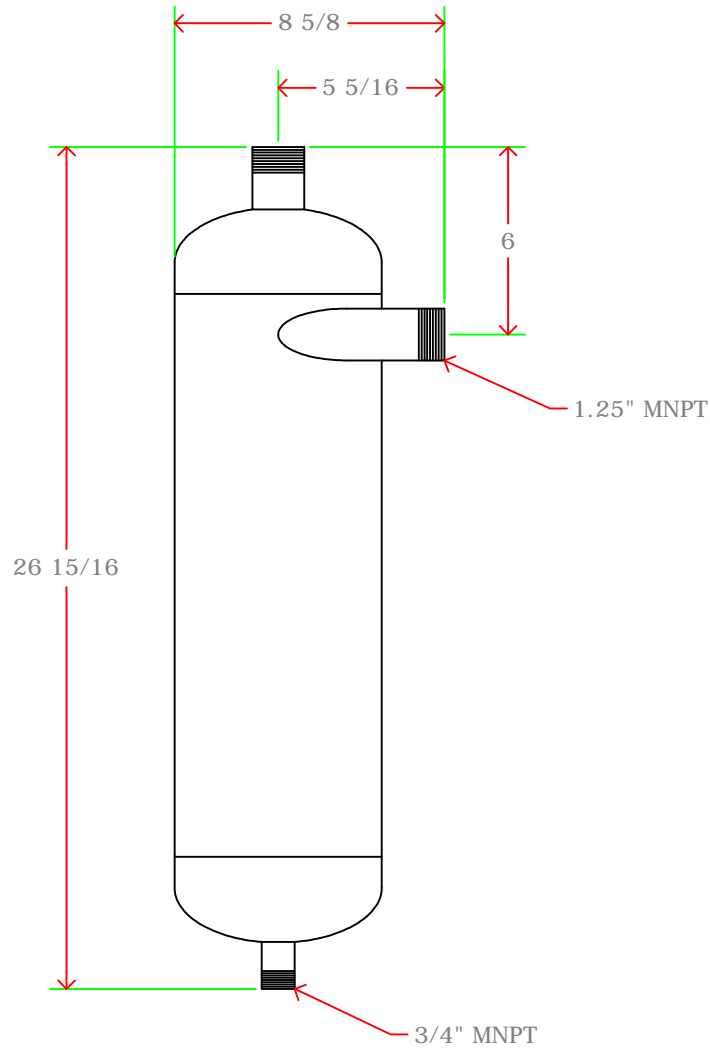
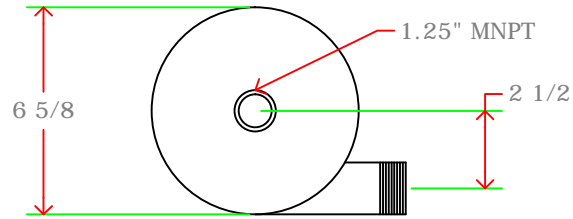

MATERIALS OF CONSTRUCTION:  
CARBON STEEL

Capacity:	x	Gallons				
Max Temp.:	200	F				
Max Press.:	150	PSI				
Weight:	133	Lbs.				
Voltage.:	x	VAC	x	Phs	x	Hz
FLA.:	x	amps				

20	x	x
19	x	x
18	x	x
17	x	x
16	x	x
15	x	x
14	x	x
13	x	x
12	x	x
11	x	x
10	x	x
9	x	x
8	x	x
7	x	x
6	x	x
5	x	x
4	x	x
3	x	x
2	x	x
1	x	x

#	PART	DESCRIPTION
F	x	xx/xx/xx
E	x	xx/xx/xx
D	x	xx/xx/xx
C	x	xx/xx/xx
B	x	xx/xx/xx

REV	DESCRIPTION	DATE
-----	-------------	------

General Treatment Products, Inc.  
PO Box 8697, Brea, CA 92822  
Phone: 714) 257-9165 <http://www.gtpcompany.com>  
Fax: 714) 257-9215 [customerservice@gtpcompany.com](mailto:customerservice@gtpcompany.com)

Date: 1/1/14 Scale: NTS Rev.: A

Description:  
1.25" 34-54 GPM THREADED SEPARATOR

Model:  
STX-0125

NOTICE: This drawing and its contents are for the specific use of GTP customers only. It is not to be duplicated or copied without expressed written consent of General Treatment Products, Inc. We reserve the right to modify this drawing without notice.

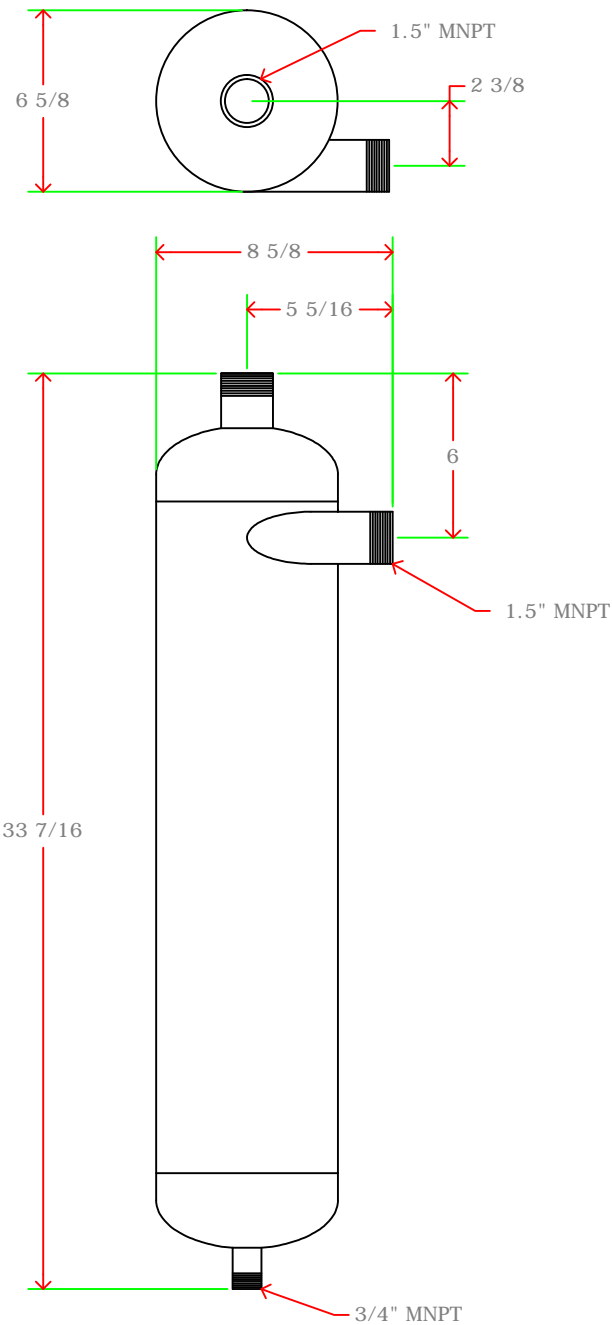

MATERIALS OF CONSTRUCTION:  
CARBON STEEL

Capacity:	x	Gallons				
Max Temp.:	200	F				
Max Press.:	150	PSI				
Weight:	135	Lbs.				
Voltage.:	x	VAC	x	Phs	x	Hz
FLA.:	x	amps				

20	x	x
19	x	x
18	x	x
17	x	x
16	x	x
15	x	x
14	x	x
13	x	x
12	x	x
11	x	x
10	x	x
9	x	x
8	x	x
7	x	x
6	x	x
5	x	x
4	x	x
3	x	x
2	x	x
1	x	x

#	PART	DESCRIPTION
F	x	xx/xx/xx
E	x	xx/xx/xx
D	x	xx/xx/xx
C	x	xx/xx/xx
B	x	xx/xx/xx

REV	DESCRIPTION	DATE
-----	-------------	------

General Treatment Products, Inc.  
 PO Box 8697, Brea, CA 92822  
 Phone: 714) 257-9165 <http://www.gtpcompany.com>  
 Fax: 714) 257-9215 [customerservice@gtpcompany.com](mailto:customerservice@gtpcompany.com)

Date: 1/1/14 Scale: NTS Rev.: A

Description:  
1.5" 52-86 GPM THREADED SEPARATOR

Model:  
STX-0150

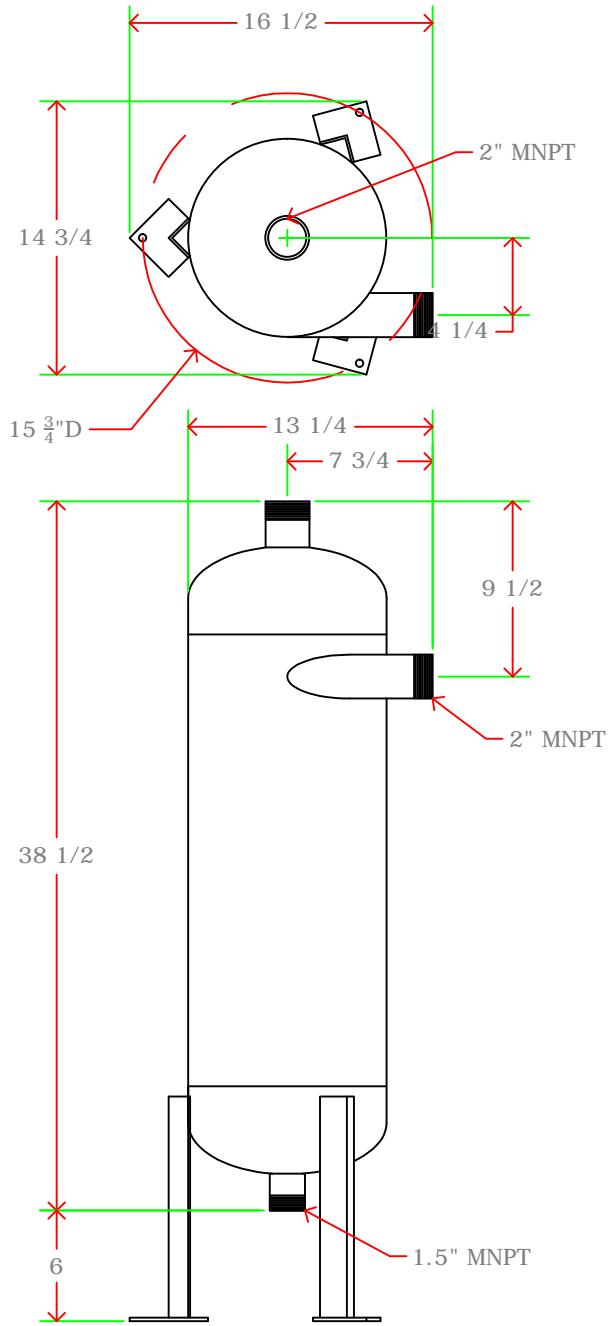
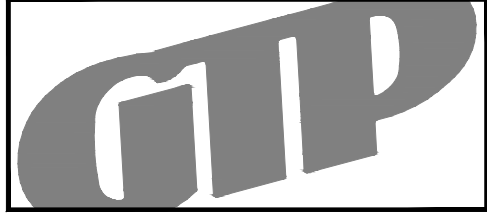

**MATERIALS OF CONSTRUCTION:**  
**CARBON STEEL**

Capacity:	x	Gallons				
Max Temp.:	200	F				
Max Press.:	150	PSI				
Weight:	148	Lbs.				
Voltage.:	x	VAC	x	Phs	x	Hz
FLA.:	x	amps				

20	x	x
19	x	x
18	x	x
17	x	x
16	x	x
15	x	x
14	x	x
13	x	x
12	x	x
11	x	x
10	x	x
9	x	x
8	x	x
7	x	x
6	x	x
5	x	x
4	x	x
3	x	x
2	x	x
1	x	x

#	PART	DESCRIPTION
F	x	xx/xx/xx
E	x	xx/xx/xx
D	x	xx/xx/xx
C	x	xx/xx/xx
B	x	xx/xx/xx

General Treatment Products, Inc.  
 PO Box 8697, Brea, CA 92822  
 Phone: 714) 257-9165      <http://www.gtpcompany.com>  
 Fax: 714) 257-9215      [customerservice@gtpcompany.com](mailto:customerservice@gtpcompany.com)

Date: 1/1/14      Scale: NTS      Rev.: A

Description:  
**2" 76-118GPM THREADED SEPARATOR**

Model:  
**STX-0200**

NOTICE: This drawing and its contents are for the specific use of GTP customers only. It is not to be duplicated or copied without expressed written consent of General Treatment Products, Inc. We reserve the right to modify this drawing without notice.

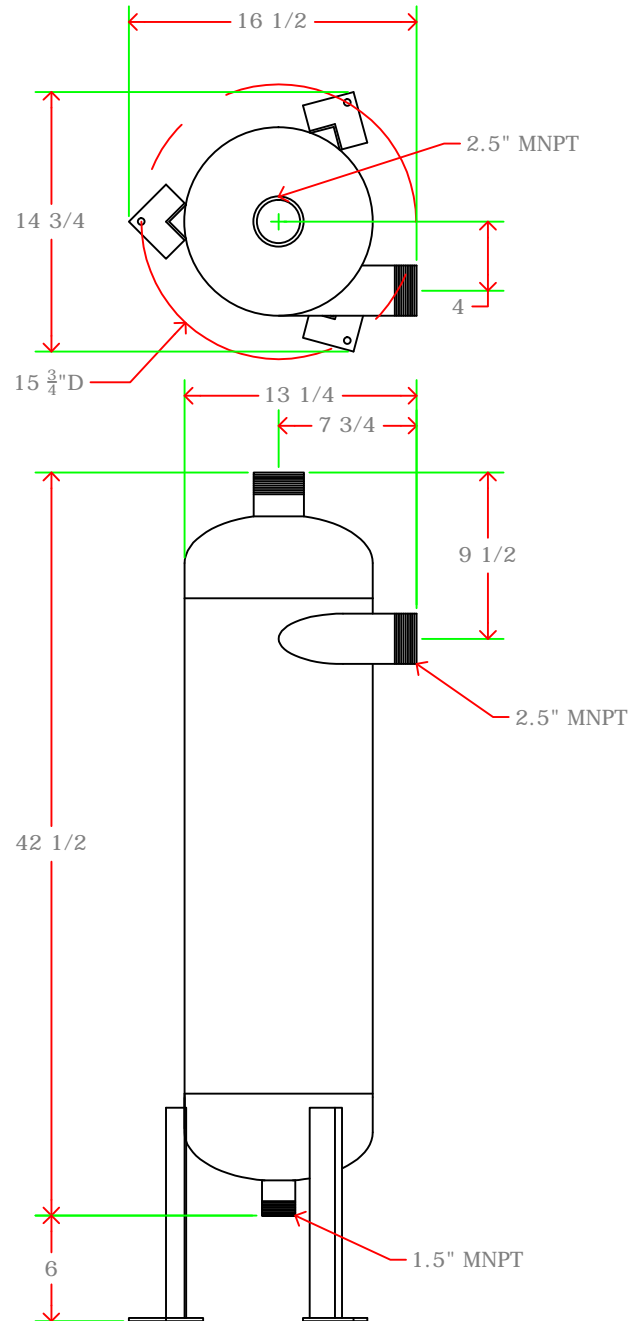
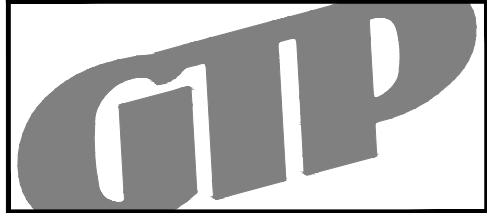

MATERIALS OF CONSTRUCTION:  
CARBON STEEL

Capacity:	x	Gallons				
Max Temp.:	200	F				
Max Press.:	150	PSI				
Weight:	163	Lbs.				
Voltage.:	x	VAC	x	Phs	x	Hz
FLA.:	x	amps				

20	x	x
19	x	x
18	x	x
17	x	x
16	x	x
15	x	x
14	x	x
13	x	x
12	x	x
11	x	x
10	x	x
9	x	x
8	x	x
7	x	x
6	x	x
5	x	x
4	x	x
3	x	x
2	x	x
1	x	x

#	PART	DESCRIPTION
F	x	xx/xx/xx
E	x	xx/xx/xx
D	x	xx/xx/xx
C	x	xx/xx/xx
B	x	xx/xx/xx
REV	DESCRIPTION	DATE

General Treatment Products, Inc.  
PO Box 8697, Brea, CA 92822  
Phone: 714) 257-9165 <http://www.gtpcompany.com>  
Fax: 714) 257-9215 [customerservice@gtpcompany.com](mailto:customerservice@gtpcompany.com)

Date: 1/1/14 Scale: NTS Rev.: A

Description:  
2.5" 118-186GPM THREADED SEPARATOR

Model:  
STX-0250

NOTICE: This drawing and its contents are for the specific use of GTP customers only. It is not to be duplicated or copied without expressed written consent of General Treatment Products, Inc. We reserve the right to modify this drawing without notice.



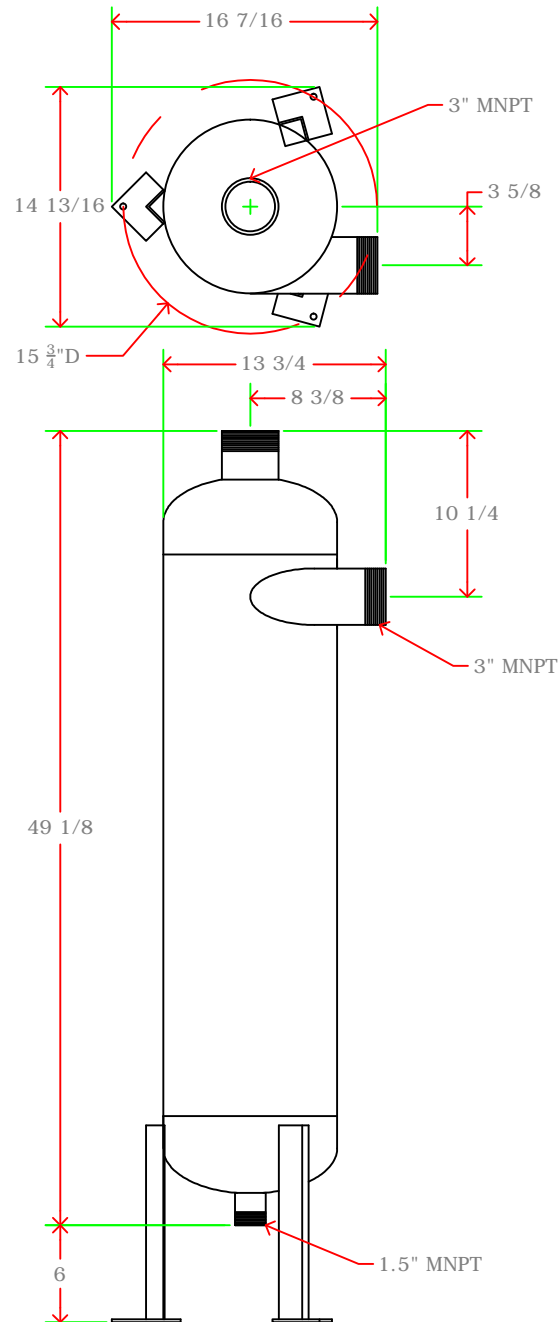
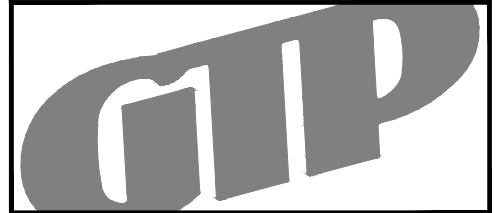

MATERIALS OF CONSTRUCTION:  
CARBON STEEL

Capacity:	x	Gallons				
Max Temp.:	200	F				
Max Press.:	150	PSI				
Weight:	200	Lbs.				
Voltage.:	x	VAC	x	Phs	x	Hz
FLA.:	x	amps				

20	x	x
19	x	x
18	x	x
17	x	x
16	x	x
15	x	x
14	x	x
13	x	x
12	x	x
11	x	x
10	x	x
9	x	x
8	x	x
7	x	x
6	x	x
5	x	x
4	x	x
3	x	x
2	x	x
1	x	x

#	PART	DESCRIPTION
F	x	xx/xx/xx
E	x	xx/xx/xx
D	x	xx/xx/xx
C	x	xx/xx/xx
B	x	xx/xx/xx

General Treatment Products, Inc.  
 PO Box 8697, Brea, CA 92822  
 Phone: 714) 257-9165  
 Fax: 714) 257-9215  
<http://www.gtpcompany.com>  
[customerservice@gtpcompany.com](mailto:customerservice@gtpcompany.com)

Date: 1/1/14 Scale: NTS Rev.: A

Description:  
3" 185-320GPM THREADED SEPARATOR

Model:  
STX-0300

NOTICE: This drawing and its contents are for the specific use of GTP customers only. It is not to be duplicated or copied without expressed written consent of General Treatment Products, Inc. We reserve the right to modify this drawing without notice.

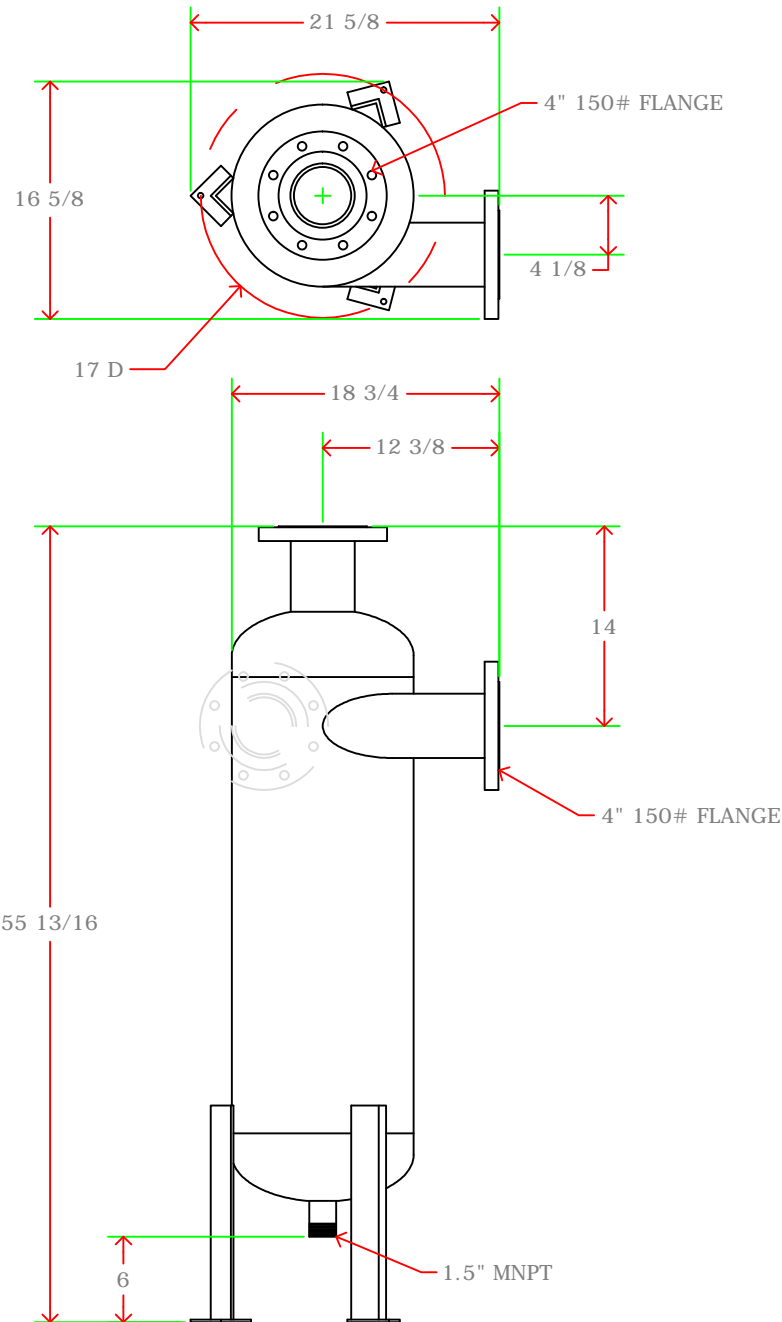
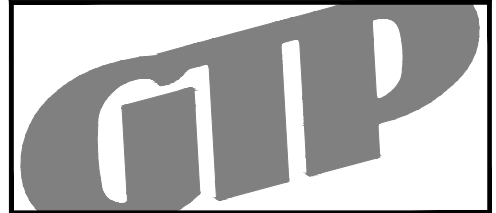

MATERIALS OF CONSTRUCTION:  
CARBON STEEL

Capacity:	x	Gallons				
Max Temp.:	200	F				
Max Press.:	150	PSI				
Weight:	290	Lbs.				
Voltage.:	x	VAC	x	Phs	x	Hz
FLA.:	x	amps				

20	x	x
19	x	x
18	x	x
17	x	x
16	x	x
15	x	x
14	x	x
13	x	x
12	x	x
11	x	x
10	x	x
9	x	x
8	x	x
7	x	x
6	x	x
5	x	x
4	x	x
3	x	x
2	x	x
1	x	x

#	PART	DESCRIPTION
F	x	xx/xx/xx
E	x	xx/xx/xx
D	x	xx/xx/xx
C	x	xx/xx/xx
B	x	xx/xx/xx

REV	DESCRIPTION	DATE
-----	-------------	------

General Treatment Products, Inc.  
PO Box 8697, Brea, CA 92822  
Phone: 714) 257-9165 <http://www.gtpcompany.com>  
Fax: 714) 257-9215 [customerservice@gtpcompany.com](mailto:customerservice@gtpcompany.com)

Date: 1/1/14 Scale: NTS Rev.: A

Description:  
4" 350-610GPM FLANGED SEPARATOR

Model:  
SFX-0400

NOTICE: This drawing and its contents are for the specific use of GTP customers only. It is not to be duplicated or copied without expressed written consent of General Treatment Products, Inc. We reserve the right to modify this drawing without notice.

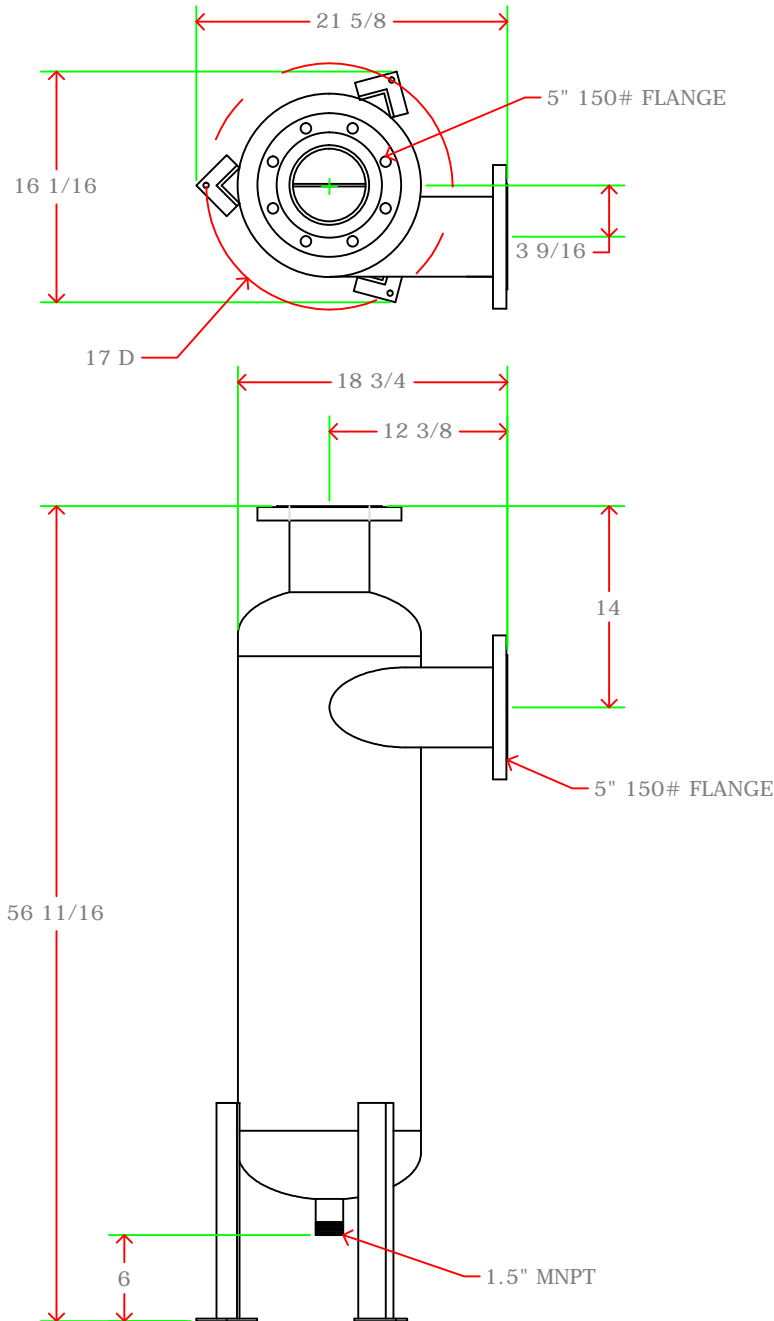
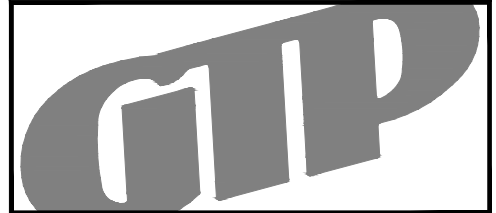

MATERIALS OF CONSTRUCTION:  
CARBON STEEL

Capacity:	x	Gallons				
Max Temp.:	200	F				
Max Press.:	150	PSI				
Weight:	330	Lbs.				
Voltage.:	x	VAC	x	Phs	x	Hz
FLA.:	x	amps				

20	x	x
19	x	x
18	x	x
17	x	x
16	x	x
15	x	x
14	x	x
13	x	x
12	x	x
11	x	x
10	x	x
9	x	x
8	x	x
7	x	x
6	x	x
5	x	x
4	x	x
3	x	x
2	x	x
1	x	x

#	PART	DESCRIPTION
F	x	xx/xx/xx
E	x	xx/xx/xx
D	x	xx/xx/xx
C	x	xx/xx/xx
B	x	xx/xx/xx

REV	DESCRIPTION	DATE
-----	-------------	------

General Treatment Products, Inc.  
 PO Box 8697, Brea, CA 92822  
 Phone: 714) 257-9165 <http://www.gtpcompany.com>  
 Fax: 714) 257-9215 [customerservice@gtpcompany.com](mailto:customerservice@gtpcompany.com)

Date: 1/1/14 Scale: NTS Rev.: A

Description:  
5" 550-960GPM FLANGED SEPARATOR

Model:  
SFX-0500

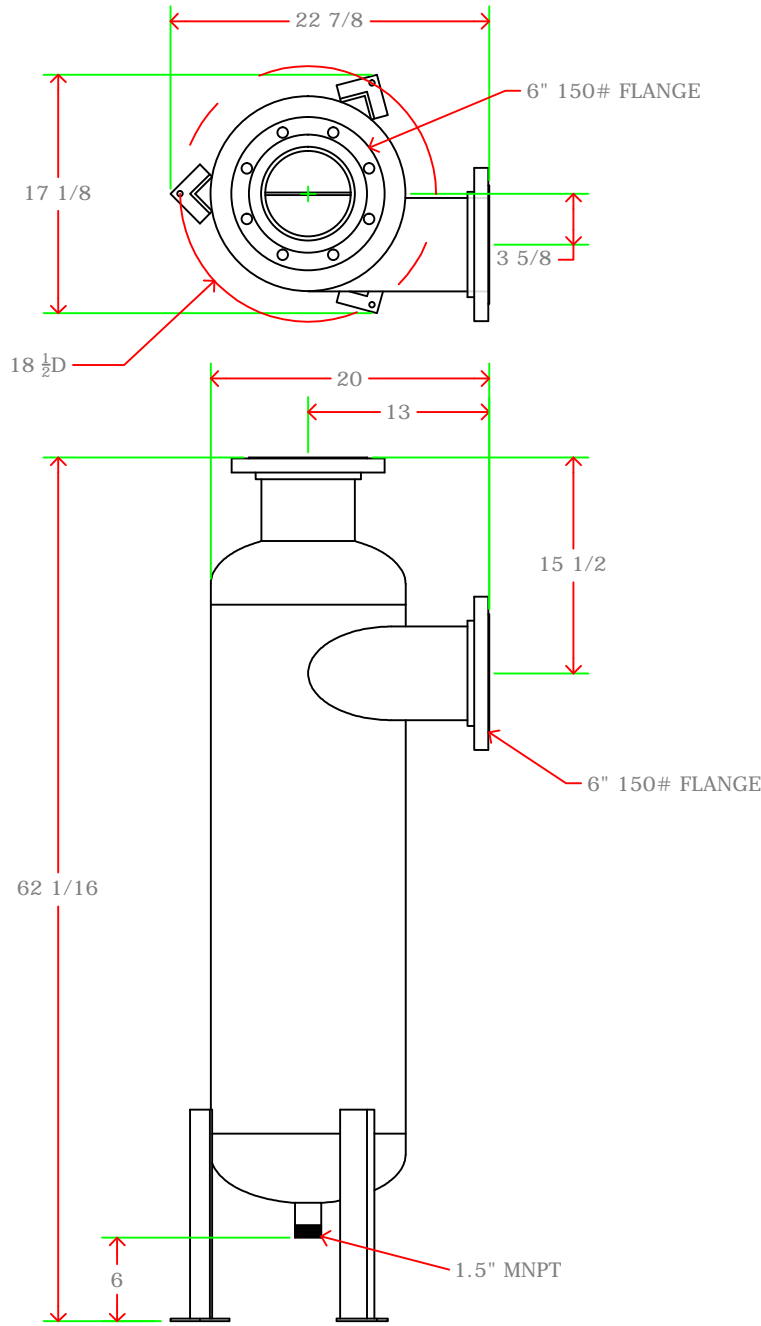
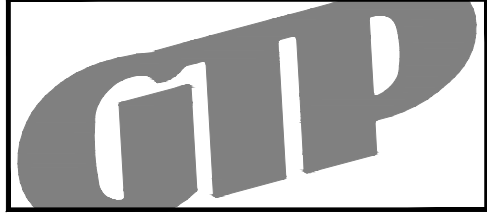

**MATERIALS OF CONSTRUCTION:**  
**CARBON STEEL**

Capacity:	x	Gallons				
Max Temp.:	200	F				
Max Press.:	150	PSI				
Weight:	330	Lbs.				
Voltage.:	x	VAC	x	Phs	x	Hz
FLA.:	x	amps				

20	x	x
19	x	x
18	x	x
17	x	x
16	x	x
15	x	x
14	x	x
13	x	x
12	x	x
11	x	x
10	x	x
9	x	x
8	x	x
7	x	x
6	x	x
5	x	x
4	x	x
3	x	x
2	x	x
1	x	x

#	PART	DESCRIPTION
F	x	xx/xx/xx
E	x	xx/xx/xx
D	x	xx/xx/xx
C	x	xx/xx/xx
B	x	xx/xx/xx

General Treatment Products, Inc.  
 PO Box 8697, Brea, CA 92822  
 Phone: 714) 257-9165      <http://www.gtpcompany.com>  
 Fax: 714) 257-9215      [customerservice@gtpcompany.com](mailto:customerservice@gtpcompany.com)

Date: 1/1/14      Scale: NTS      Rev.: A

Description:  
**6" 800-1390GPM FLANGED SEPARATOR**

Model:  
**SFX-0600**

NOTICE: This drawing and its contents are for the specific use of GTP customers only. It is not to be duplicated or copied without expressed written consent of General Treatment Products, Inc. We reserve the right to modify this drawing without notice.

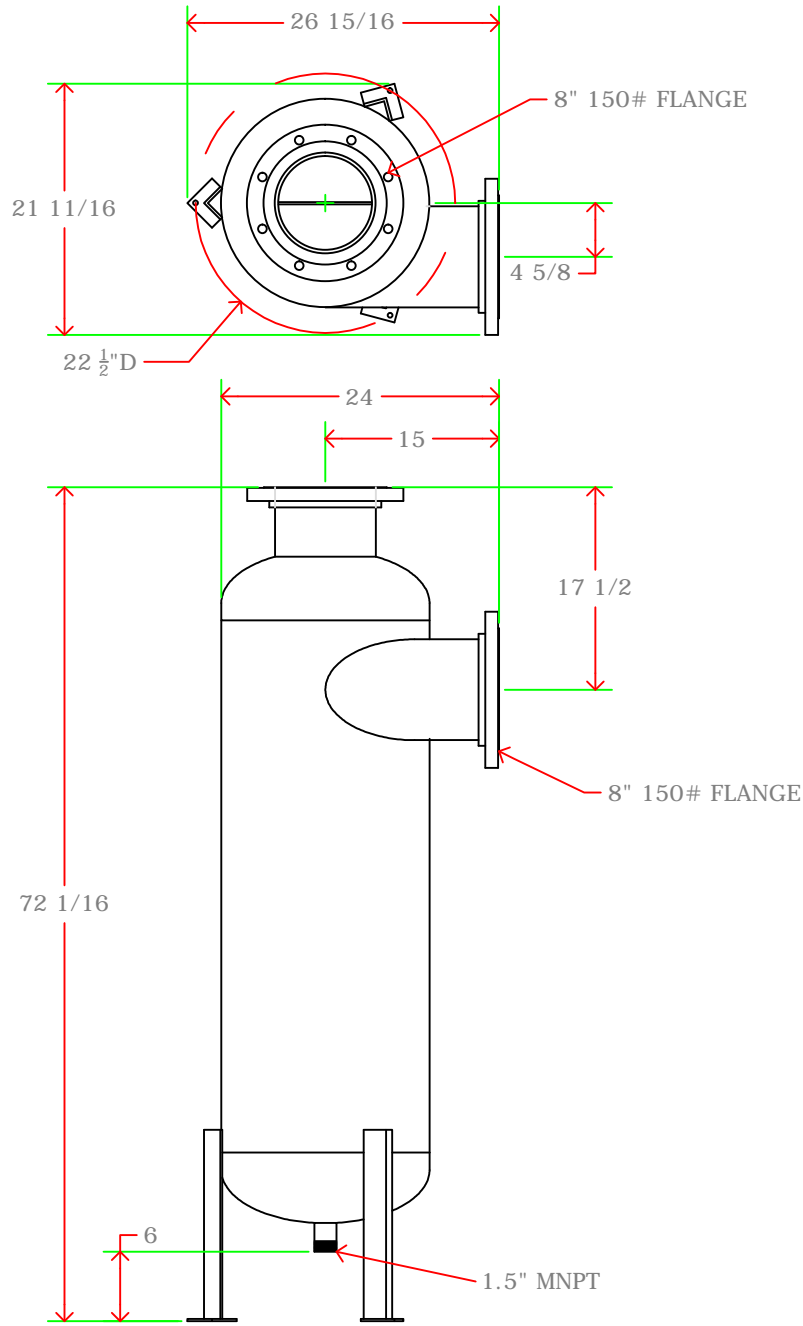

**MATERIALS OF CONSTRUCTION:**  
**CARBON STEEL**

Capacity:	x	Gallons				
Max Temp.:	200	F				
Max Press.:	150	PSI				
Weight:	480	Lbs.				
Voltage.:	x	VAC	x	Phs	x	Hz
FLA.:	x	amps				

20	x	x
19	x	x
18	x	x
17	x	x
16	x	x
15	x	x
14	x	x
13	x	x
12	x	x
11	x	x
10	x	x
9	x	x
8	x	x
7	x	x
6	x	x
5	x	x
4	x	x
3	x	x
2	x	x
1	x	x

#	PART	DESCRIPTION
F	x	xx/xx/xx
E	x	xx/xx/xx
D	x	xx/xx/xx
C	x	xx/xx/xx
B	x	xx/xx/xx

General Treatment Products, Inc.  
 PO Box 8697, Brea, CA 92822  
 Phone: 714) 257-9165 <http://www.gtpcompany.com>  
 Fax: 714) 257-9215 [customerservice@gtpcompany.com](mailto:customerservice@gtpcompany.com)

Date: 1/1/14 Scale: NTS Rev.: A

Description:  
**8" 1380-2400GPM FLANGED SEPARATOR**

Model:  
**SFX-0800**

NOTICE: This drawing and its contents are for the specific use of GTP customers only. It is not to be duplicated or copied without expressed written consent of General Treatment Products, Inc. We reserve the right to modify this drawing without notice.

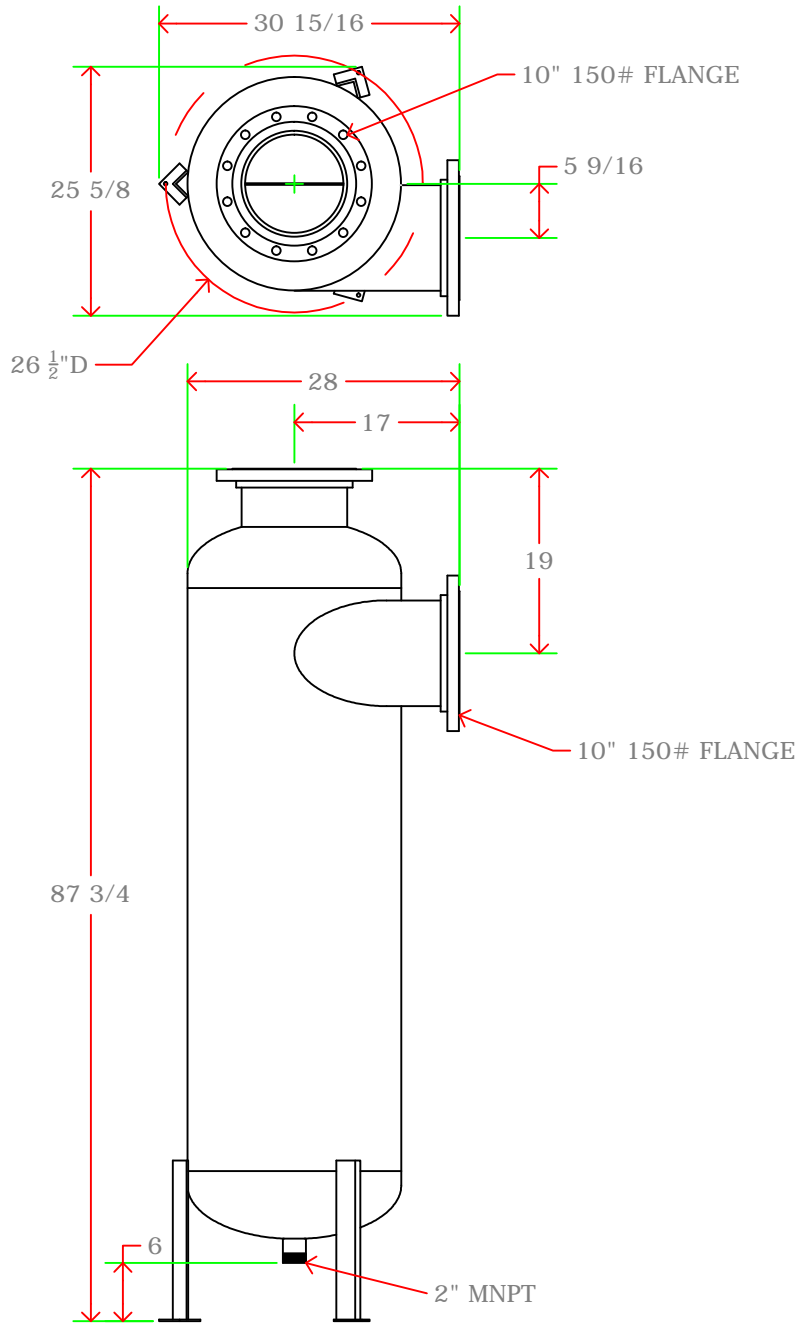

MATERIALS OF CONSTRUCTION:  
**CARBON STEEL**

Capacity:	x	Gallons				
Max Temp.:	200	F				
Max Press.:	150	PSI				
Weight:	575	Lbs.				
Voltage.:	x	VAC	x	Phs	x	Hz
FLA.:	x	amps				

20	x	x
19	x	x
18	x	x
17	x	x
16	x	x
15	x	x
14	x	x
13	x	x
12	x	x
11	x	x
10	x	x
9	x	x
8	x	x
7	x	x
6	x	x
5	x	x
4	x	x
3	x	x
2	x	x
1	x	x

#	PART	DESCRIPTION
F	x	xx/xx/xx
E	x	xx/xx/xx
D	x	xx/xx/xx
C	x	xx/xx/xx
B	x	xx/xx/xx
REV	DESCRIPTION	DATE

General Treatment Products, Inc.  
 PO Box 8697, Brea, CA 92822  
 Phone: 714) 257-9165 <http://www.gtpcompany.com>  
 Fax: 714) 257-9215 [customerservice@gtpcompany.com](mailto:customerservice@gtpcompany.com)

Date: 1/1/14 Scale: NTS Rev.: A

Description:  
**10" 2175-3780GPM FLANGED SEPARATOR**

Model:  
**SFX-1000**

NOTICE: This drawing and its contents are for the specific use of GTP customers only. It is not to be duplicated or copied without expressed written consent of General Treatment Products, Inc. We reserve the right to modify this drawing without notice.

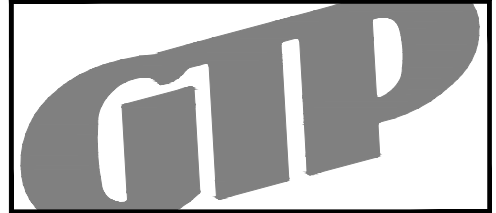
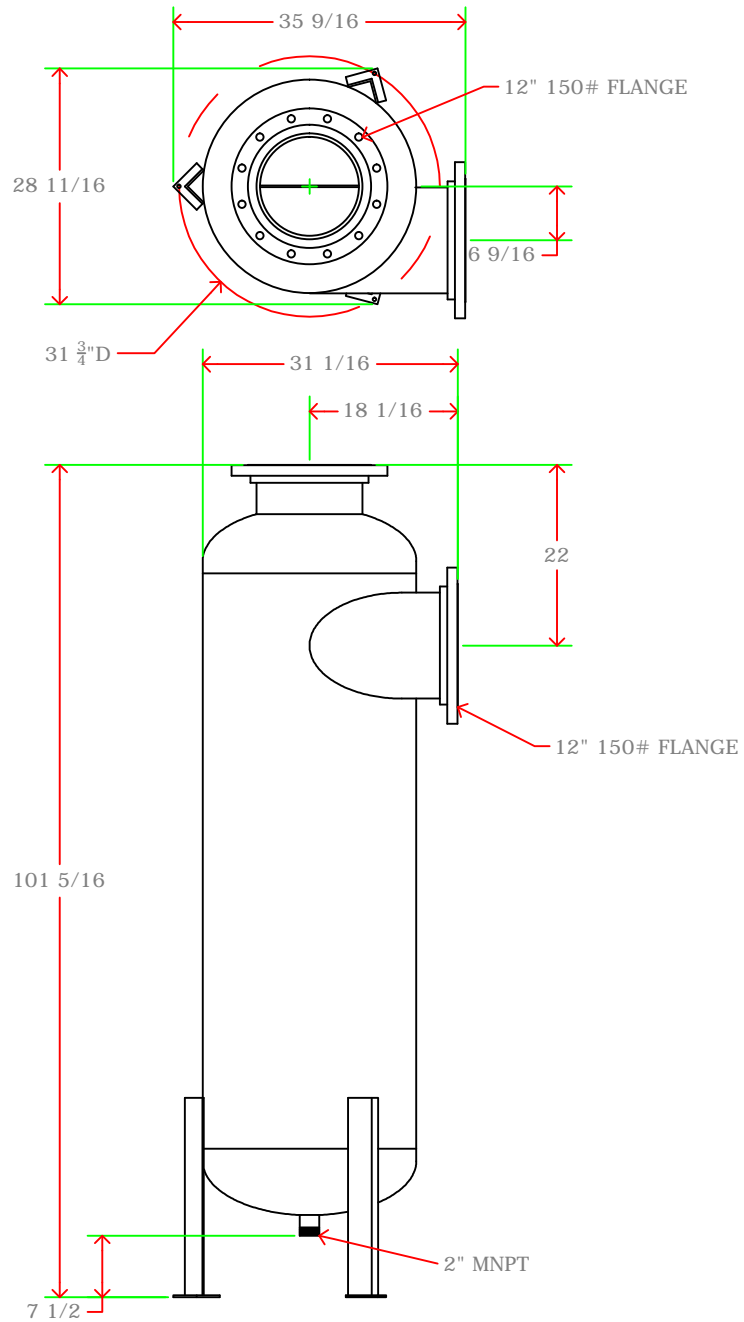

MATERIALS OF CONSTRUCTION:  
CARBON STEEL

Capacity:	x	Gallons				
Max Temp.:	200	F				
Max Press.:	150	PSI				
Weight:	855	Lbs.				
Voltage.:	x	VAC	x	Phs	x	Hz
FLA.:	x	amps				

20	x	x
19	x	x
18	x	x
17	x	x
16	x	x
15	x	x
14	x	x
13	x	x
12	x	x
11	x	x
10	x	x
9	x	x
8	x	x
7	x	x
6	x	x
5	x	x
4	x	x
3	x	x
2	x	x
1	x	x

#	PART	DESCRIPTION
F	x	xx/xx/xx
E	x	xx/xx/xx
D	x	xx/xx/xx
C	x	xx/xx/xx
B	x	xx/xx/xx
REV	DESCRIPTION	DATE

General Treatment Products, Inc.  
PO Box 8697, Brea, CA 92822  
Phone: 714) 257-9165 <http://www.gtpcompany.com>  
Fax: 714) 257-9215 [customerservice@gtpcompany.com](mailto:customerservice@gtpcompany.com)

Date: 1/1/14 Scale: NTS Rev.: A

Description:  
12" 2910-5050GPM FLANGED SEPARATOR

Model:  
SFX-1200

NOTICE: This drawing and its contents are for the specific use of GTP customers only. It is not to be duplicated or copied without expressed written consent of General Treatment Products, Inc. We reserve the right to modify this drawing without notice.

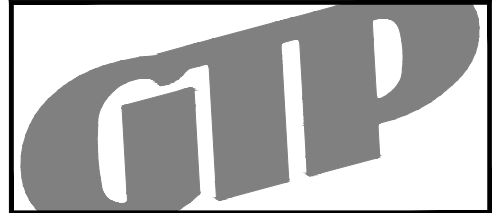
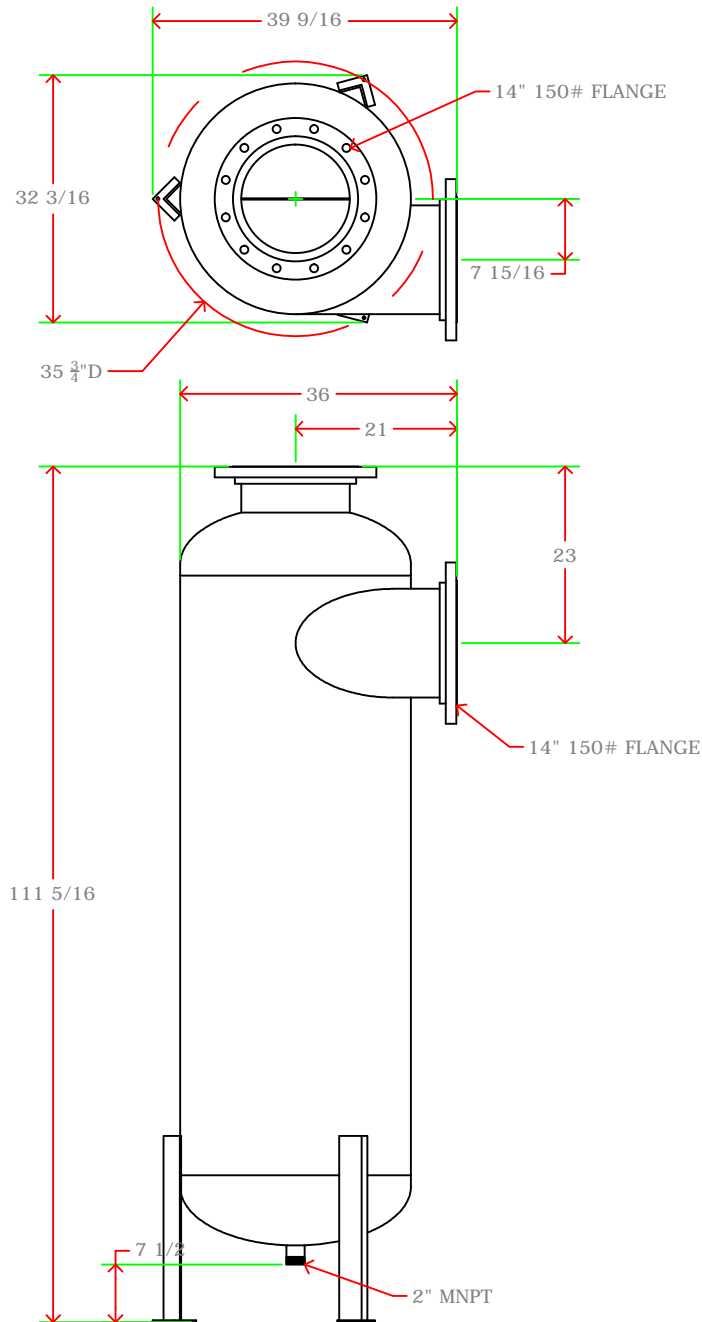

MATERIALS OF CONSTRUCTION:  
CARBON STEEL

Capacity:	x	Gallons				
Max Temp.:	200	F				
Max Press.:	150	PSI				
Weight:	1390	Lbs.				
Voltage.:	x	VAC	x	Phs	x	Hz
FLA.:	x	amps				

20	x	x
19	x	x
18	x	x
17	x	x
16	x	x
15	x	x
14	x	x
13	x	x
12	x	x
11	x	x
10	x	x
9	x	x
8	x	x
7	x	x
6	x	x
5	x	x
4	x	x
3	x	x
2	x	x
1	x	x

#	PART	DESCRIPTION
F	x	xx/xx/xx
E	x	xx/xx/xx
D	x	xx/xx/xx
C	x	xx/xx/xx
B	x	xx/xx/xx

REV	DESCRIPTION	DATE
-----	-------------	------

General Treatment Products, Inc.  
 PO Box 8697, Brea, CA 92822  
 Phone: 714) 257-9165 <http://www.gtpcompany.com>  
 Fax: 714) 257-9215 [customerservice@gtpcompany.com](mailto:customerservice@gtpcompany.com)

Date: 1/1/14 Scale: NTS Rev.: A

Description:  
14" 3810-6600GPM FLANGED SEPARATOR

Model:  
SFX-1400



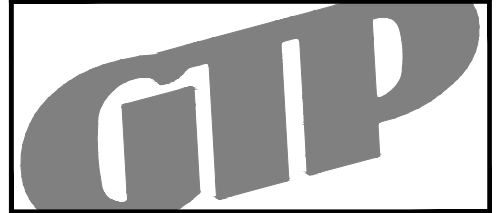
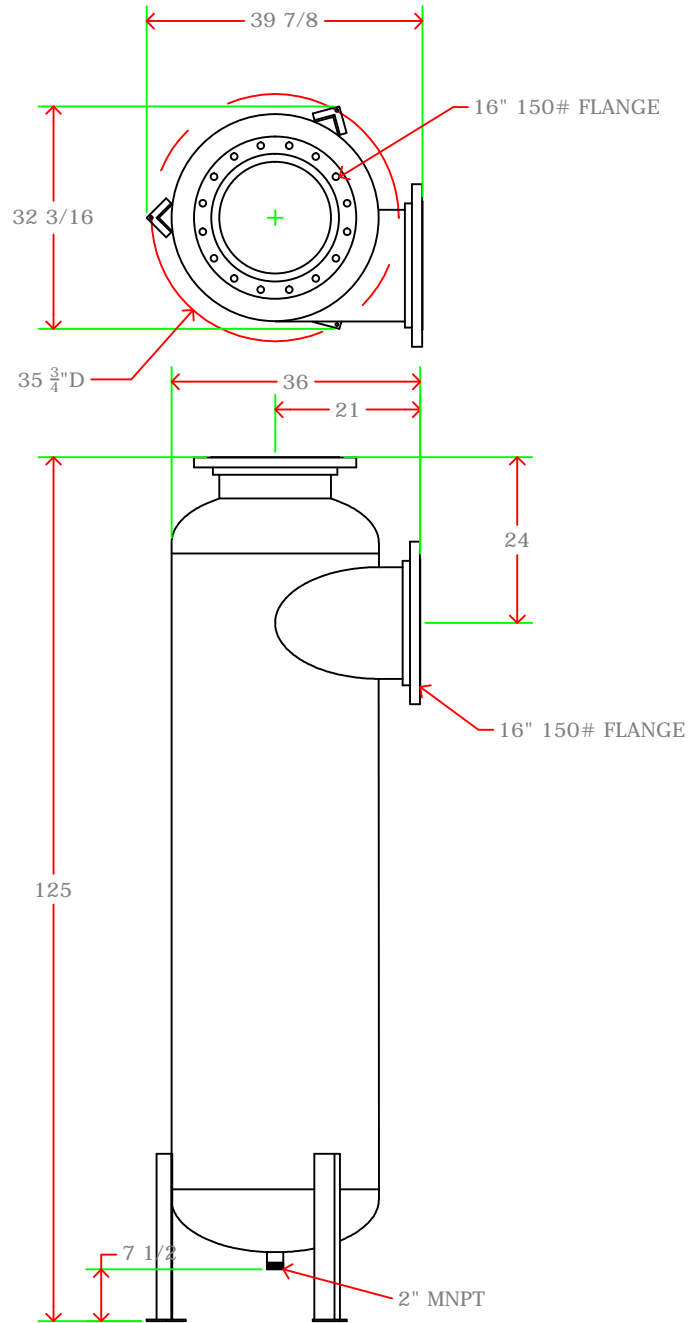

MATERIALS OF CONSTRUCTION:  
**CARBON STEEL**

Capacity:	x	Gallons				
Max Temp.:	200	F				
Max Press.:	150	PSI				
Weight:	1650	Lbs.				
Voltage.:	x	VAC	x	Phs	x	Hz
FLA.:	x	amps				

20	x	x
19	x	x
18	x	x
17	x	x
16	x	x
15	x	x
14	x	x
13	x	x
12	x	x
11	x	x
10	x	x
9	x	x
8	x	x
7	x	x
6	x	x
5	x	x
4	x	x
3	x	x
2	x	x
1	x	x

#	PART	DESCRIPTION
F	x	xx/xx/xx
E	x	xx/xx/xx
D	x	xx/xx/xx
C	x	xx/xx/xx
B	x	xx/xx/xx

REV	DESCRIPTION	DATE
-----	-------------	------

General Treatment Products, Inc.  
 PO Box 8697, Brea, CA 92822  
 Phone: 714) 257-9165 <http://www.gtpcompany.com>  
 Fax: 714) 257-9215 [customerservice@gtpcompany.com](mailto:customerservice@gtpcompany.com)

Date: 1/1/14 Scale: NTS Rev.: A

Description:  
**16" 5050-8760GPM FLANGED SEPARATOR**

Model:  
**SFX-1600**

NOTICE: This drawing and it's contents are for the specific use of GTP customers only. It is not to be duplicated or copied without expressed written concent or General Treatment Products, Inc. We reserve the right to modify this drawing without notice.

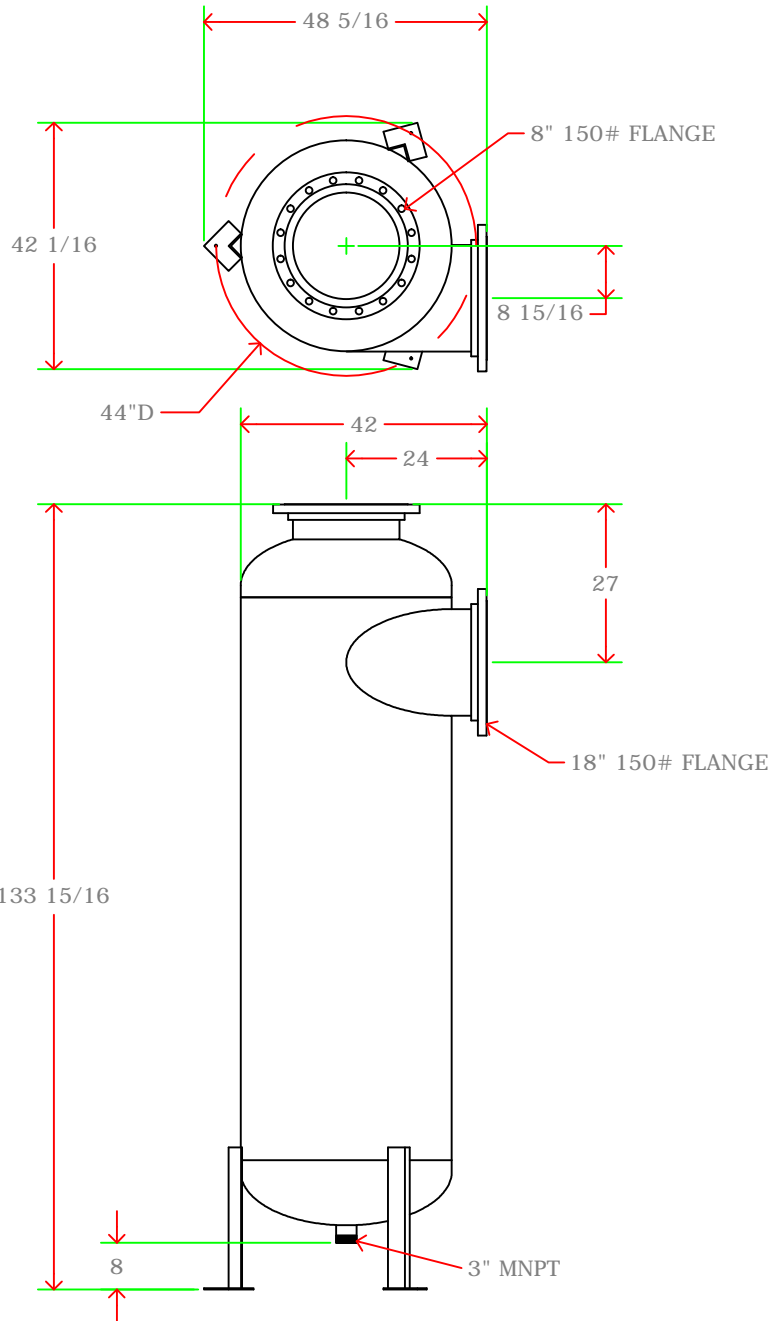
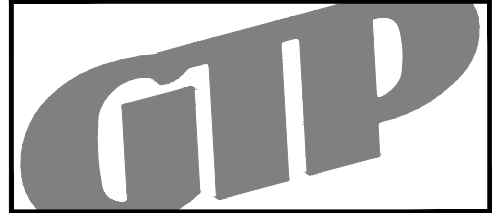

MATERIALS OF CONSTRUCTION:  
CARBON STEEL

Capacity:	x	Gallons				
Max Temp.:	200	F				
Max Press.:	150	PSI				
Weight:	2150	Lbs.				
Voltage.:	x	VAC	x	Phs	x	Hz
FLA.:	x	amps				

20	x	x
19	x	x
18	x	x
17	x	x
16	x	x
15	x	x
14	x	x
13	x	x
12	x	x
11	x	x
10	x	x
9	x	x
8	x	x
7	x	x
6	x	x
5	x	x
4	x	x
3	x	x
2	x	x
1	x	x

#	PART	DESCRIPTION
F	x	xx/xx/xx
E	x	xx/xx/xx
D	x	xx/xx/xx
C	x	xx/xx/xx
B	x	xx/xx/xx

REV	DESCRIPTION	DATE
-----	-------------	------

General Treatment Products, Inc.  
PO Box 8697, Brea, CA 92822  
Phone: 714) 257-9165 <http://www.gtpcompany.com>  
Fax: 714) 257-9215 [customerservice@gtpcompany.com](mailto:customerservice@gtpcompany.com)

Date: 1/1/14 Scale: NTS Rev.: A

Description:  
**18" 6500-11200GPM FLANGED SEPARATOR**

Model:  
**SFX-1800**

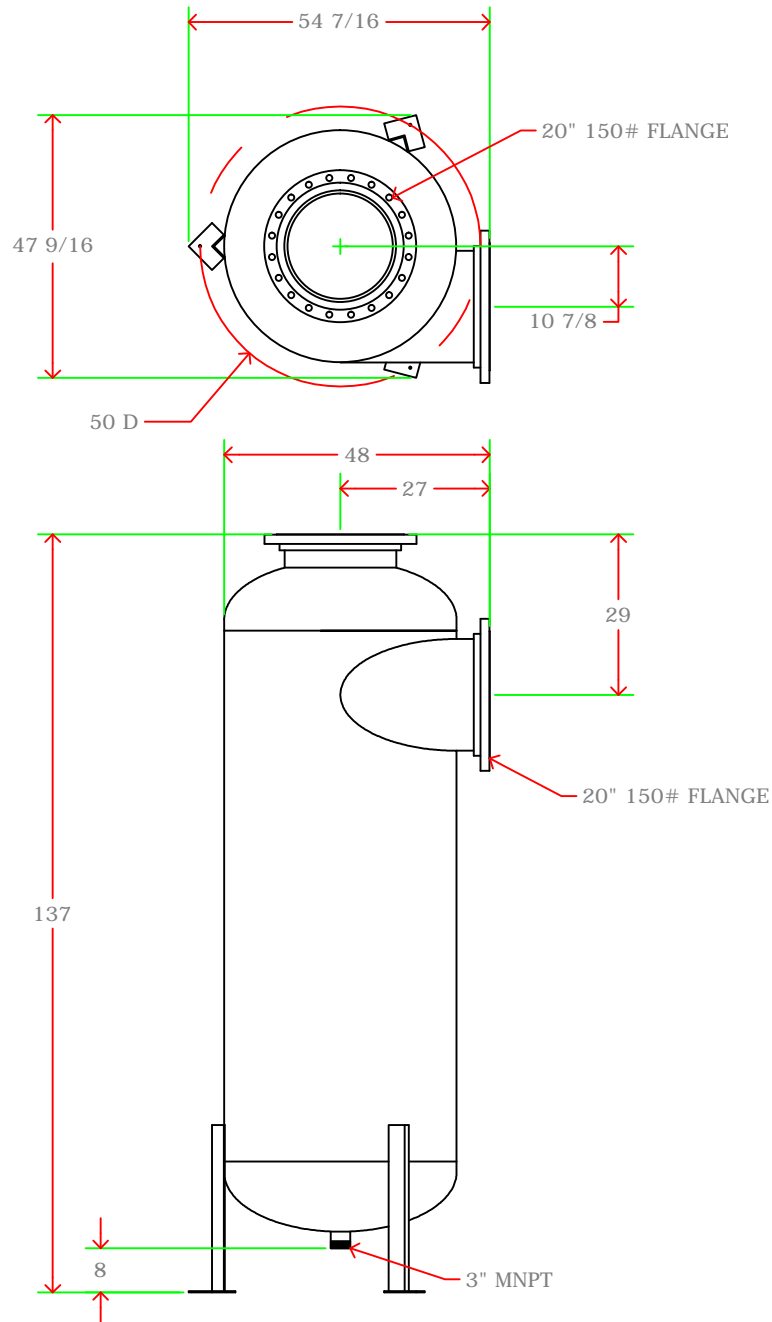
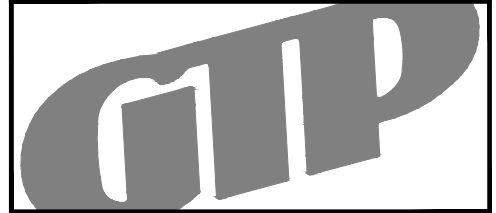

MATERIALS OF CONSTRUCTION:  
CARBON STEEL

Capacity:	x	Gallons				
Max Temp.:	200	F				
Max Press.:	150	PSI				
Weight:	2652	Lbs.				
Voltage.:	x	VAC	x	Phs	x	Hz
FLA.:	x	amps				

20	x	x
19	x	x
18	x	x
17	x	x
16	x	x
15	x	x
14	x	x
13	x	x
12	x	x
11	x	x
10	x	x
9	x	x
8	x	x
7	x	x
6	x	x
5	x	x
4	x	x
3	x	x
2	x	x
1	x	x

#	PART	DESCRIPTION
F	x	xx/xx/xx
E	x	xx/xx/xx
D	x	xx/xx/xx
C	x	xx/xx/xx
B	x	xx/xx/xx
REV	DESCRIPTION	DATE

General Treatment Products, Inc.  
PO Box 8097, Brea, CA 92822  
Phone: 714) 257-9165 <http://www.gtpcompany.com>  
Fax: 714) 257-9215 [customerservice@gtpcompany.com](mailto:customerservice@gtpcompany.com)

Date: 1/1/14 Scale: NTS Rev.: A

Description:  
**20" 8050-13950GPM FLANGED SEPARATOR**

Model:  
**SFX-2000**