

**MATERIALS OF CONSTRUCTION:**  
 CARBON STEEL, EPDM GASKETS, BRASS,  
 STAINLESS STEEL, POLYESTER FELT

**SYSTEM INFORMATION:**  
 2HP, TEFC, 3500RPM PUMP  
 2" FLANGED SUCTION  
 1.25" FLANGED DISCHARGE  
 2GL CONTINUOUS PURGE RECOVERY TANK

**Capacity:** 40 GPM  
**Max Temp.:** 85 F  
**Max Press.:** 120 PSI  
**Weight:** 720 Lbs.  
**Voltage.:** 230 VAC 3 Phs 60 Hz  
**FLA.:** 5.0 amps

20	x	x
19	x	x
18	x	x
17	x	x
16	x	x
15	x	x
14	x	x
13	x	x
12	x	x
11	x	x
10	x	x
9	x	x
8	x	x
7	x	x
6	x	x
5	x	x
4	x	x
3	x	x
2	x	x
1	x	x

#	PART	DESCRIPTION
F	x	xx/xx/xx
E	x	xx/xx/xx
D	x	xx/xx/xx
C	x	xx/xx/xx
B	x	xx/xx/xx

REV	DESCRIPTION	DATE
-----	-------------	------

General Treatment Products, Inc.  
 PO Box 8697, Brea, CA 92822  
 Phone: 714) 257-9165 <http://www.gtpcompany.com>  
 Fax: 714) 257-9215 [customerservice@gtpcompany.com](mailto:customerservice@gtpcompany.com)

Date: 1/1/16 Scale: NTS Rev.: A

Description:  
 TOWER CLEAN SEPARATOR PACKAGE

Model:  
 TCS-0040

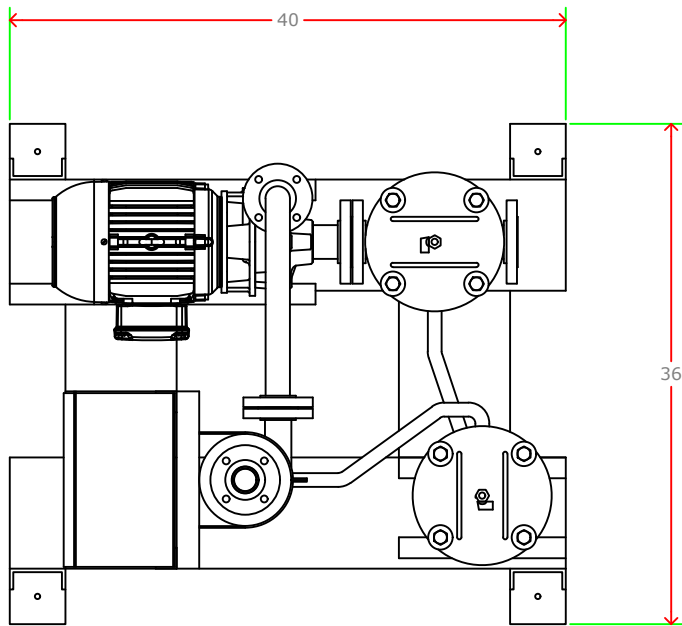
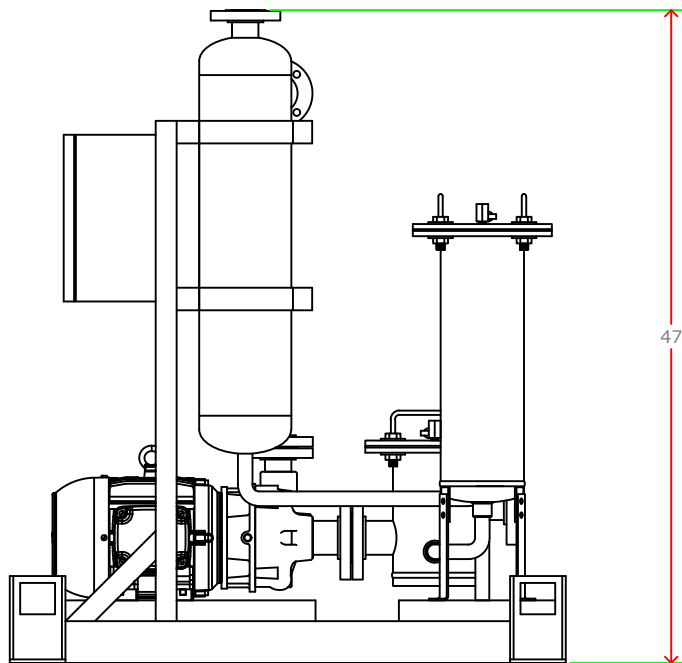

**MATERIALS OF CONSTRUCTION:**  
 CARBON STEEL, EPDM GASKETS, BRASS,  
 STAINLESS STEEL, POLYESTER FELT

**SYSTEM INFORMATION:**  
 3HP, TEFC, 3500RPM PUMP  
 2" FLANGED SUCTION  
 1.5" FLANGED DISCHARGE  
 2GL CONTINUOUS PURGE RECOVERY TANK

**Capacity:** 65 GPM  
**Max Temp.:** 85 F  
**Max Press.:** 120 PSI  
**Weight:** 780 Lbs.  
**Voltage.:** 230 VAC 3 Phs 60 Hz  
**FLA.:** 7.2 amps

20	x	x
19	x	x
18	x	x
17	x	x
16	x	x
15	x	x
14	x	x
13	x	x
12	x	x
11	x	x
10	x	x
9	x	x
8	x	x
7	x	x
6	x	x
5	x	x
4	x	x
3	x	x
2	x	x
1	x	x

#	PART	DESCRIPTION
F	x	xx/xx/xx
E	x	xx/xx/xx
D	x	xx/xx/xx
C	x	xx/xx/xx
B	x	xx/xx/xx

REV	DESCRIPTION	DATE
-----	-------------	------

General Treatment Products, Inc.  
 PO Box 8697, Brea, CA 92822  
 Phone: 714) 257-9165 <http://www.gtpcompany.com>  
 Fax: 714) 257-9215 [customerservice@gtpcompany.com](mailto:customerservice@gtpcompany.com)

Date: 1/1/16 Scale: NTS Rev.: A

Description:  
 TOWER CLEAN SEPARATOR PACKAGE

Model:  
 TCS-0065

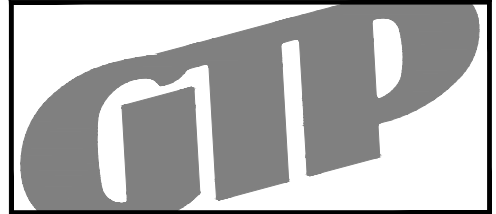

**MATERIALS OF CONSTRUCTION:**  
 CARBON STEEL, EPDM GASKETS, BRASS,  
 STAINLESS STEEL, POLYESTER FELT

**SYSTEM INFORMATION:**  
 5HP, TEFC, 3500RPM PUMP  
 2" FLANGED SUCTION  
 2" FLANGED DISCHARGE  
 2GL CONTINUOUS PURGE RECOVERY TANK

**Capacity:** 100 GPM  
**Max Temp.:** 85 F  
**Max Press.:** 120 PSI  
**Weight:** 815 Lbs.  
**Voltage.:** 230 VAC 3 Phs 60 Hz  
**FLA.:** 11.8 amps

20	x	x
19	x	x
18	x	x
17	x	x
16	x	x
15	x	x
14	x	x
13	x	x
12	x	x
11	x	x
10	x	x
9	x	x
8	x	x
7	x	x
6	x	x
5	x	x
4	x	x
3	x	x
2	x	x
1	x	x

#	PART	DESCRIPTION
F	x	xx/xx/xx
E	x	xx/xx/xx
D	x	xx/xx/xx
C	x	xx/xx/xx
B	x	xx/xx/xx

REV	DESCRIPTION	DATE
-----	-------------	------

General Treatment Products, Inc.  
 PO Box 8697, Brea, CA 92822  
 Phone: 714) 257-9165 <http://www.gtpcompany.com>  
 Fax: 714) 257-9215 [customerservice@gtpcompany.com](mailto:customerservice@gtpcompany.com)

Date: 1/1/16 Scale: NTS Rev.: A

Description:  
 TOWER CLEAN SEPARATOR PACKAGE

Model:  
 TCS-0100

