

**MATERIALS OF CONSTRUCTION:**  
CARBON STEEL

<b>Capacity:</b>	6-12 Gallons
<b>Max Temp.:</b>	200 F
<b>Max Press.:</b>	150 PSI
<b>Weight:</b>	113 Lbs.
<b>Voltage.:</b>	x VAC x Phs x Hz
<b>FLA.:</b>	x amps

20	x	x
19	x	x
18	x	x
17	x	x
16	x	x
15	x	x
14	x	x
13	x	x
12	x	x
11	x	x
10	x	x
9	x	x
8	x	x
7	x	x
6	x	x
5	x	x
4	x	x
3	x	x
2	x	x
1	x	x

#	PART	DESCRIPTION
F	x	xx/xx/xx
E	x	xx/xx/xx
D	x	xx/xx/xx
C	x	xx/xx/xx
B	x	xx/xx/xx
REV	DESCRIPTION	DATE

General Treatment Products, Inc.  
PO Box 8697, Brea, CA 92822  
Phone: 714) 257-9165 <http://www.gtpcompany.com>  
Fax: 714) 257-9215 [customerservice@gtpcompany.com](mailto:customerservice@gtpcompany.com)

Date: 1/1/14 Scale: NTS Rev.: A

Description:  
1/2" 6-12 GPM FLANGED SEPARATOR

Model:  
SFX-0050

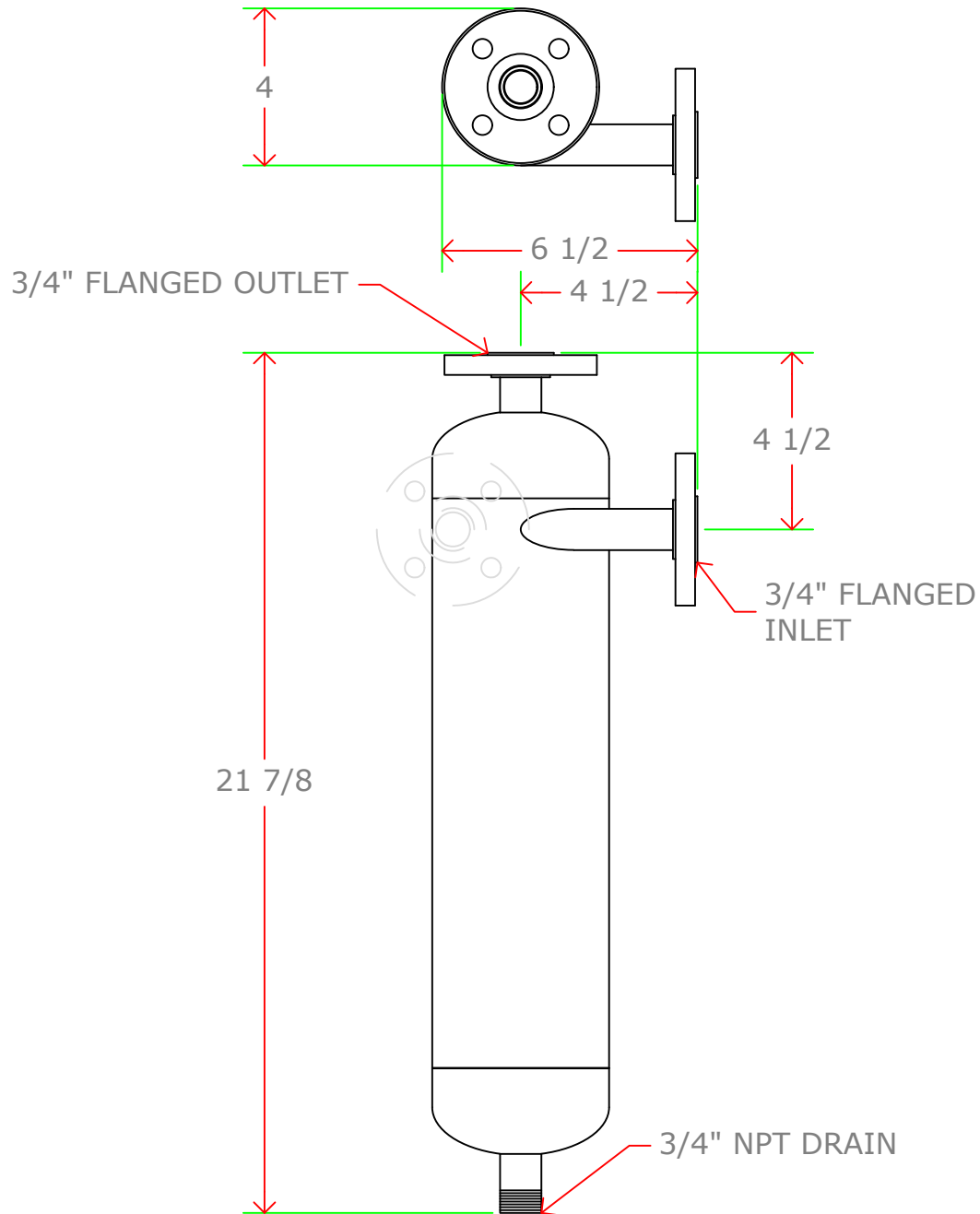
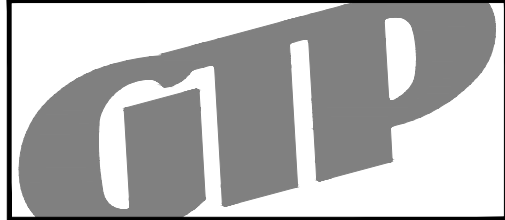

**MATERIALS OF CONSTRUCTION:**  
CARBON STEEL

**Capacity:** 12-23 Gallons  
**Max Temp.:** 200 F  
**Max Press.:** 150 PSI  
**Weight:** 124 Lbs.  
**Voltage.:** x VAC x Phs x Hz  
**FLA.:** x amps

20	x	x
19	x	x
18	x	x
17	x	x
16	x	x
15	x	x
14	x	x
13	x	x
12	x	x
11	x	x
10	x	x
9	x	x
8	x	x
7	x	x
6	x	x
5	x	x
4	x	x
3	x	x
2	x	x
1	x	x

#	PART	DESCRIPTION
F	x	xx/xx/xx
E	x	xx/xx/xx
D	x	xx/xx/xx
C	x	xx/xx/xx
B	x	xx/xx/xx

REV	DESCRIPTION	DATE
-----	-------------	------

General Treatment Products, Inc.  
 PO Box 8697, Brea, CA 92822  
 Phone: 714) 257-9165 <http://www.gtpcompany.com>  
 Fax: 714) 257-9215 [customerservice@gtpcompany.com](mailto:customerservice@gtpcompany.com)

Date: 1/1/14 Scale: NTS Rev.: A

Description:  
3/4" 12-23 GPM FLANGED SEPARATOR

Model:  
STX-0075

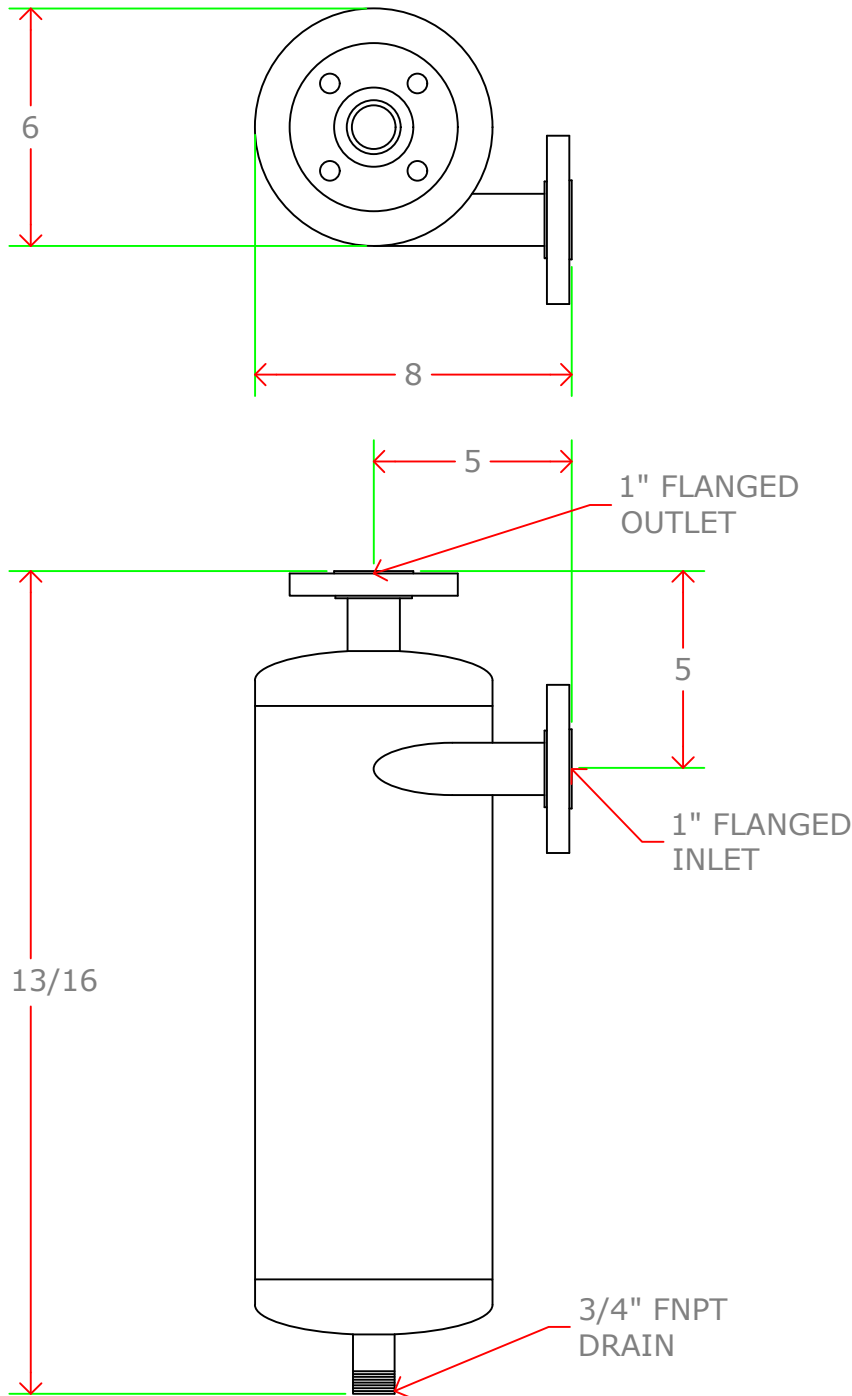
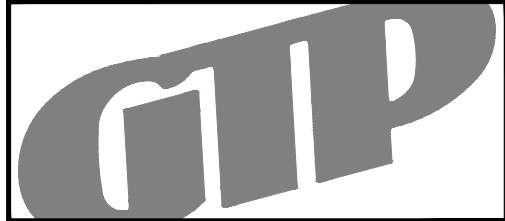

**MATERIALS OF CONSTRUCTION:**  
CARBON STEEL

**Capacity:** 22-38 Gallons  
**Max Temp.:** 200 F  
**Max Press.:** 150 PSI  
**Weight:** 130 Lbs.  
**Voltage.:** x VAC x Phs x Hz  
**FLA.:** x amps

20	x	x
19	x	x
18	x	x
17	x	x
16	x	x
15	x	x
14	x	x
13	x	x
12	x	x
11	x	x
10	x	x
9	x	x
8	x	x
7	x	x
6	x	x
5	x	x
4	x	x
3	x	x
2	x	x
1	x	x

#	PART	DESCRIPTION
F	x	xx/xx/xx
E	x	xx/xx/xx
D	x	xx/xx/xx
C	x	xx/xx/xx
B	x	xx/xx/xx

REV	DESCRIPTION	DATE
-----	-------------	------

General Treatment Products, Inc.  
 PO Box 8697, Brea, CA 92822  
 Phone: 714) 257-9165 <http://www.gtpcompany.com>  
 Fax: 714) 257-9215 [customerservice@gtpcompany.com](mailto:customerservice@gtpcompany.com)

Date: 1/1/14 Scale: NTS Rev.: A

Description:  
1" 22-38 GPM FLANGED SEPARATOR

Model:  
STX-0100

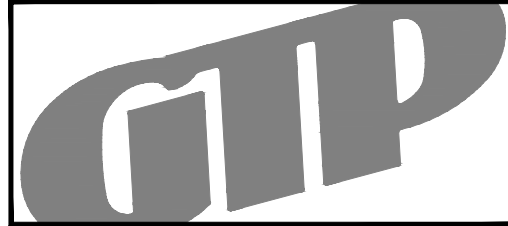
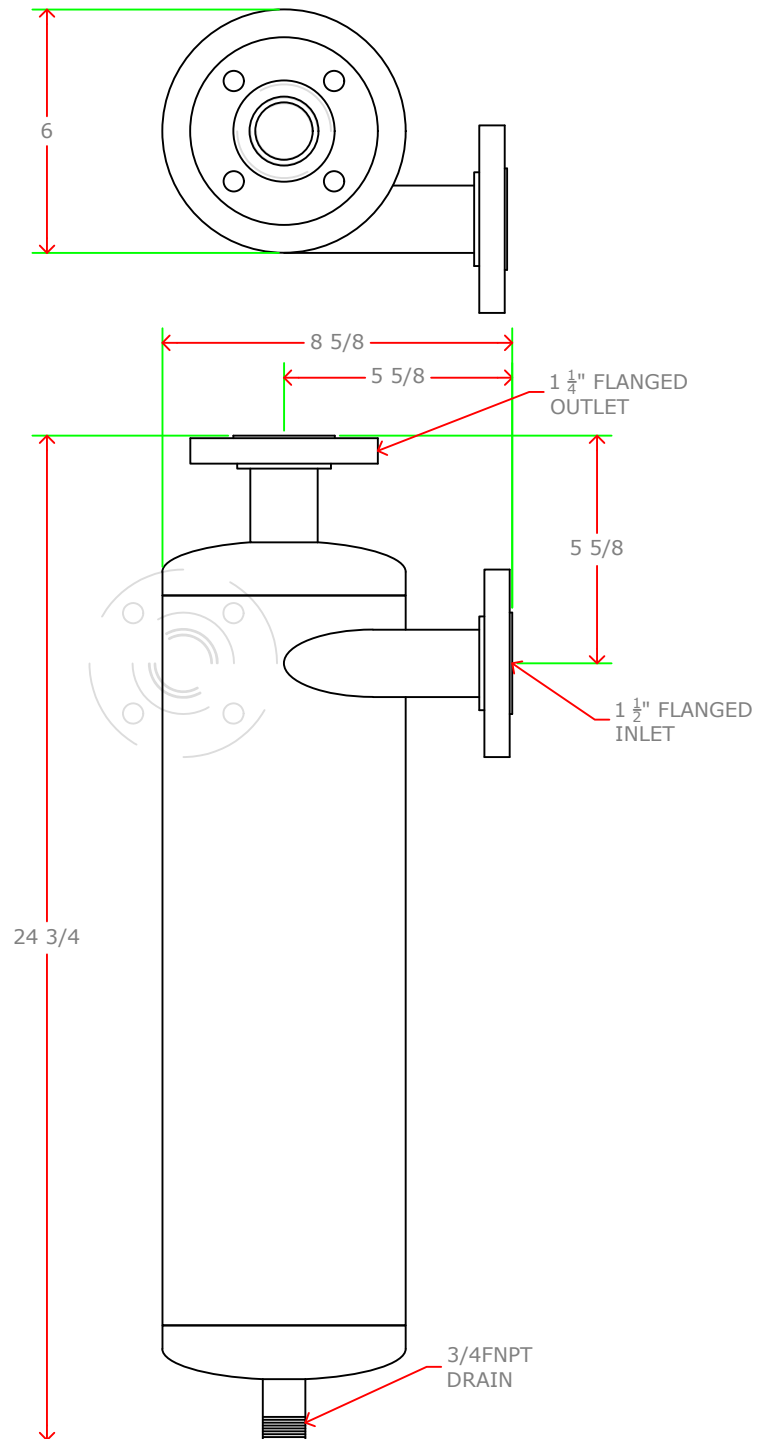

**MATERIALS OF CONSTRUCTION:**  
**CARBON STEEL**

**Capacity:** 34-54 Gallons per Minute

**Max Temp.:** 200 F

**Max Press.:** 150 PSI

**Weight:** 178 Lbs.

**Voltage.:** x VAC x Phs x Hz

**FLA.:** x amps

20	x	x
19	x	x
18	x	x
17	x	x
16	x	x
15	x	x
14	x	x
13	x	x
12	x	x
11	x	x
10	x	x
9	x	x
8	x	x
7	x	x
6	x	x
5	x	x
4	x	x
3	x	x
2	x	x
1	x	x

#	PART	DESCRIPTION
F	x	xx/xx/xx
E	x	xx/xx/xx
D	x	xx/xx/xx
C	x	xx/xx/xx
B	x	xx/xx/xx
REV	DESCRIPTION	DATE

General Treatment Products, Inc.  
 PO Box 8697, Brea, CA 92822  
 Phone: 714) 257-9165 <http://www.gtpcompany.com>  
 Fax: 714) 257-9215 [customerservice@gtpcompany.com](mailto:customerservice@gtpcompany.com)

**Date:** 1/1/16 **Scale:** NTS **Rev.:** A

**Description:**  
 1 1/4" 34-54GPM FLANGED SEPARATOR

**Model:**  
 SFX-0125

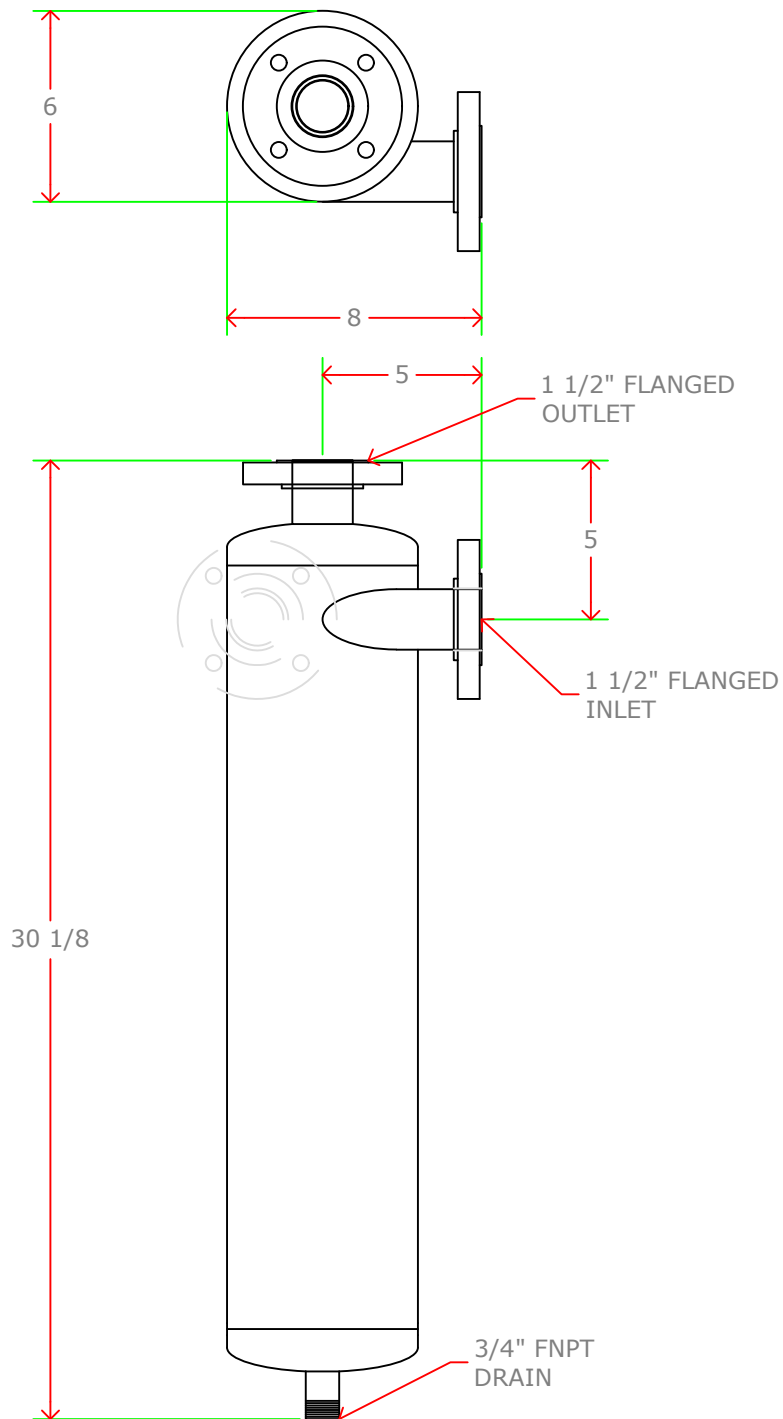

**MATERIALS OF CONSTRUCTION:**  
**CARBON STEEL**

**Capacity:** 52-86 Gallons  
**Max Temp.:** 200 F  
**Max Press.:** 150 PSI  
**Weight:** 180 Lbs.  
**Voltage.:** x VAC x Phs x Hz  
**FLA.:** x amps

20	x	x
19	x	x
18	x	x
17	x	x
16	x	x
15	x	x
14	x	x
13	x	x
12	x	x
11	x	x
10	x	x
9	x	x
8	x	x
7	x	x
6	x	x
5	x	x
4	x	x
3	x	x
2	x	x
1	x	x

#	PART	DESCRIPTION
F	x	xx/xx/xx
E	x	xx/xx/xx
D	x	xx/xx/xx
C	x	xx/xx/xx
B	x	xx/xx/xx

**General Treatment Products, Inc.**  
 PO Box 8697, Brea, CA 92822  
 Phone: 714) 257-9165 <http://www.gtpcompany.com>  
 Fax: 714) 257-9215 [customerservice@gtpcompany.com](mailto:customerservice@gtpcompany.com)

**Date:** 1/1/16 **Scale:** NTS **Rev.:** A  
**Description:**  
 1 1/2", 52-86 FLANGED SEPARATOR  
**Model:**  
 SFX-0150

NOTICE: This drawing and its contents are for the specific use of GTP customers only. It is not to be duplicated or copied without expressed written consent of General Treatment Products, Inc. We reserve the right to modify this drawing without notice.

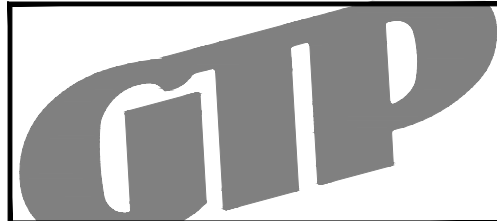
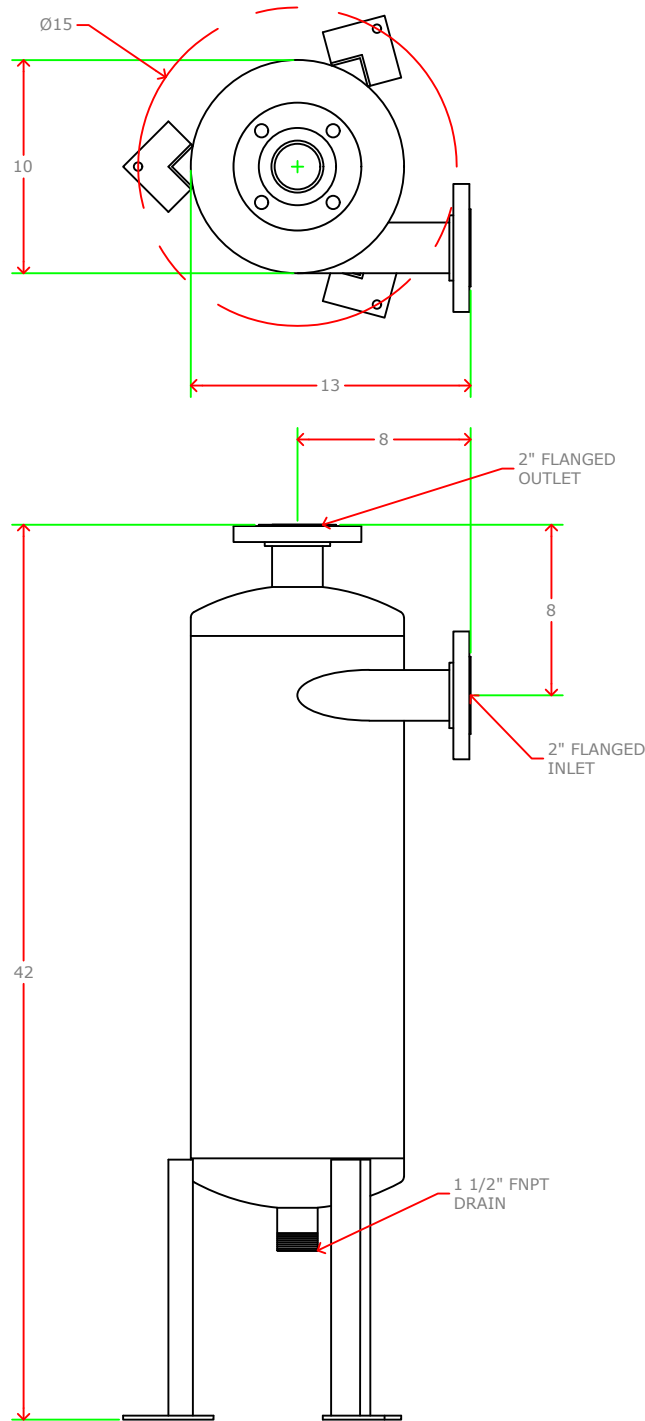

**MATERIALS OF CONSTRUCTION:**  
 CARBON STEEL

**Capacity:** 76-118 Gallons  
**Max Temp.:** 200 F  
**Max Press.:** 150 PSI  
**Weight:** 196 Lbs.  
**Voltage.:** x VAC x Phs x Hz  
**FLA.:** x amps

20	x	x
19	x	x
18	x	x
17	x	x
16	x	x
15	x	x
14	x	x
13	x	x
12	x	x
11	x	x
10	x	x
9	x	x
8	x	x
7	x	x
6	x	x
5	x	x
4	x	x
3	x	x
2	x	x
1	x	x

#	PART	DESCRIPTION
F	x	xx/xx/xx
E	x	xx/xx/xx
D	x	xx/xx/xx
C	x	xx/xx/xx
B	x	xx/xx/xx

REV	DESCRIPTION	DATE
-----	-------------	------

General Treatment Products, Inc.  
 PO Box 8697, Brea, CA 92822  
 Phone: 714) 257-9165 <http://www.gtpcompany.com>  
 Fax: 714) 257-9215 [customerservice@gtpcompany.com](mailto:customerservice@gtpcompany.com)

Date: 1/1/14 Scale: NTS Rev.: A

Description:  
 2" 76-118GPM FLANGED SEPARATOR

Model:  
 SFX-0200

NOTICE: This drawing and its contents are for the specific use of GTP customers only. It is not to be duplicated or copied without expressed written consent of General Treatment Products, Inc. We reserve the right to modify this drawing without notice.

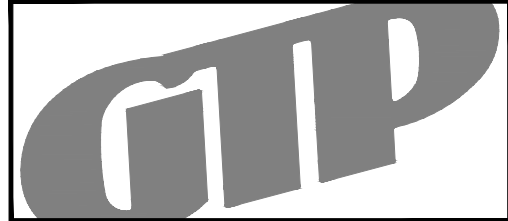
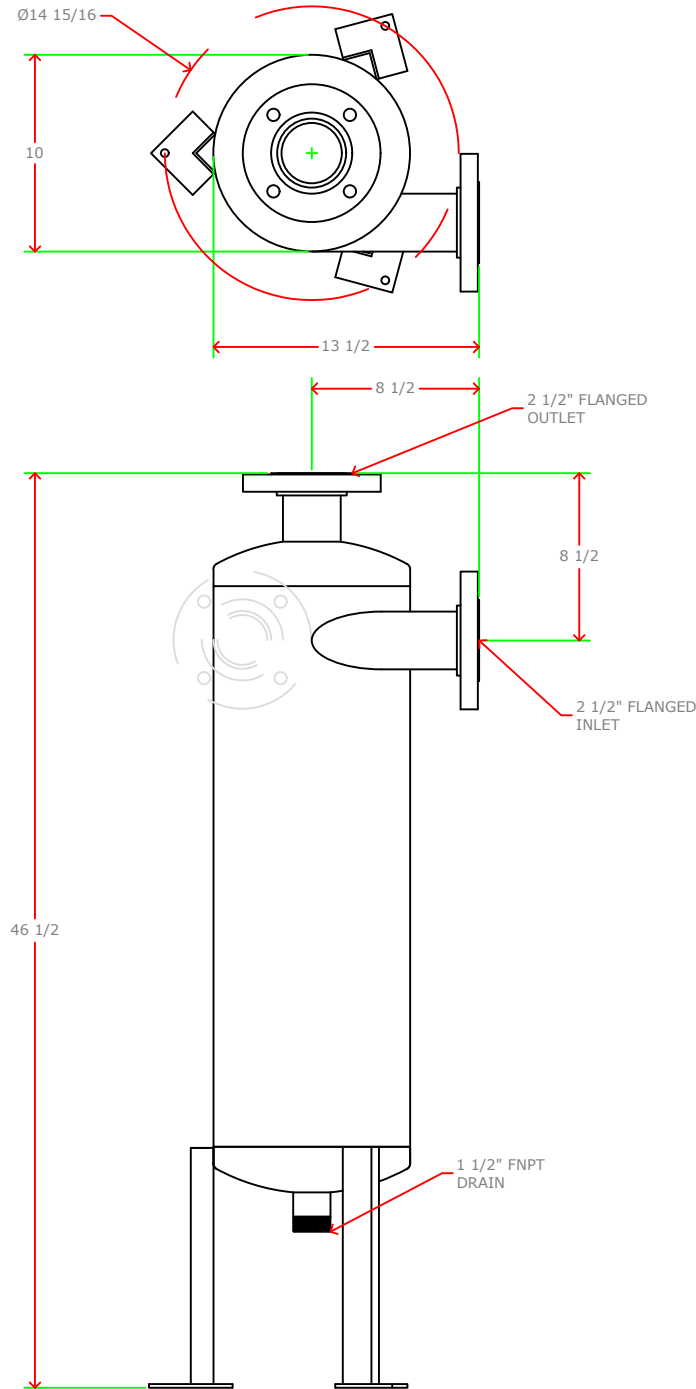

**MATERIALS OF CONSTRUCTION:**  
**CARBON STEEL**

<b>Capacity:</b>	118-186	Gallons				
<b>Max Temp.:</b>	200	F				
<b>Max Press.:</b>	150	PSI				
<b>Weight:</b>	200	Lbs.				
<b>Voltage.:</b>	x	VAC	x	Phs	x	Hz
<b>FLA.:</b>	x	amps				
20	x		x			
19	x		x			
18	x		x			
17	x		x			
16	x		x			
15	x		x			
14	x		x			
13	x		x			
12	x		x			
11	x		x			
10	x		x			
9	x		x			
8	x		x			
7	x		x			
6	x		x			
5	x		x			
4	x		x			
3	x		x			
2	x		x			
1	x		x			

#	PART	DESCRIPTION
F	x	xx/xx/xx
E	x	xx/xx/xx
D	x	xx/xx/xx
C	x	xx/xx/xx
B	x	xx/xx/xx

General Treatment Products, Inc.  
 PO Box 8697, Brea, CA 92822  
 Phone: 714) 257-9165      <http://www.gtpcompany.com>  
 Fax: 714) 257-9215      [customerservice@gtpcompany.com](mailto:customerservice@gtpcompany.com)

**Date:** xx/xx/xx      **Scale:** NTS      **Rev.:** A  
**Description:**  
**2 1/2" 118-186GPM FLANGED SEPARATOR**  
**Model:**  
**SFX-0250**

NOTICE: This drawing and its contents are for the specific use of GTP customers only. It is not to be duplicated or copied without expressed written consent of General Treatment Products, Inc. We reserve the right to modify this drawing without notice.

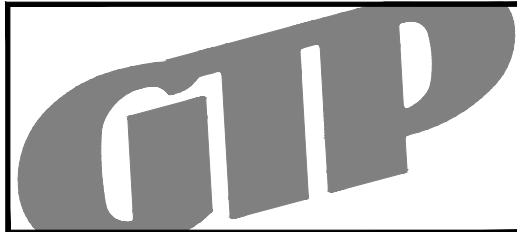
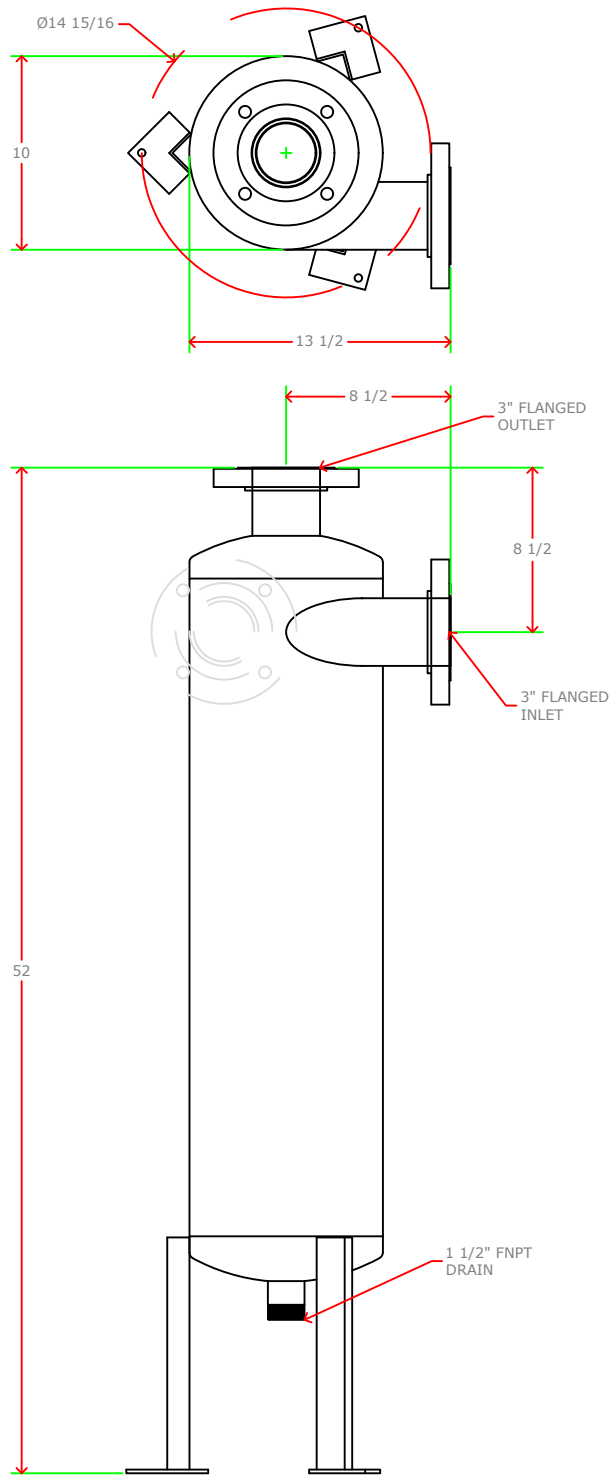

**MATERIALS OF CONSTRUCTION:**  
CARBON STEEL

<b>Capacity:</b>	185-320 Gallons
<b>Max Temp.:</b>	200 F
<b>Max Press.:</b>	150 PSI
<b>Weight:</b>	200 Lbs.
<b>Voltage.:</b>	x VAC x Phs x Hz
<b>FLA.:</b>	x amps
20	x x
19	x x
18	x x
17	x x
16	x x
15	x x
14	x x
13	x x
12	x x
11	x x
10	x x
9	x x
8	x x
7	x x
6	x x
5	x x
4	x x
3	x x
2	x x
1	x x

#	PART	DESCRIPTION
F	x	xx/xx/xx
E	x	xx/xx/xx
D	x	xx/xx/xx
C	x	xx/xx/xx
B	x	xx/xx/xx

REV	DESCRIPTION	DATE
-----	-------------	------

General Treatment Products, Inc.  
PO Box 8697, Brea, CA 92822  
Phone: 714) 257-9165 <http://www.gtpcompany.com>  
Fax: 714) 257-9215 [customerservice@gtpcompany.com](mailto:customerservice@gtpcompany.com)

Date: xx/xx/xx Scale: NTS Rev.: A

Description:  
3" 185-320GPMFLANGED SEPARATOR

Model:  
SFX-0300



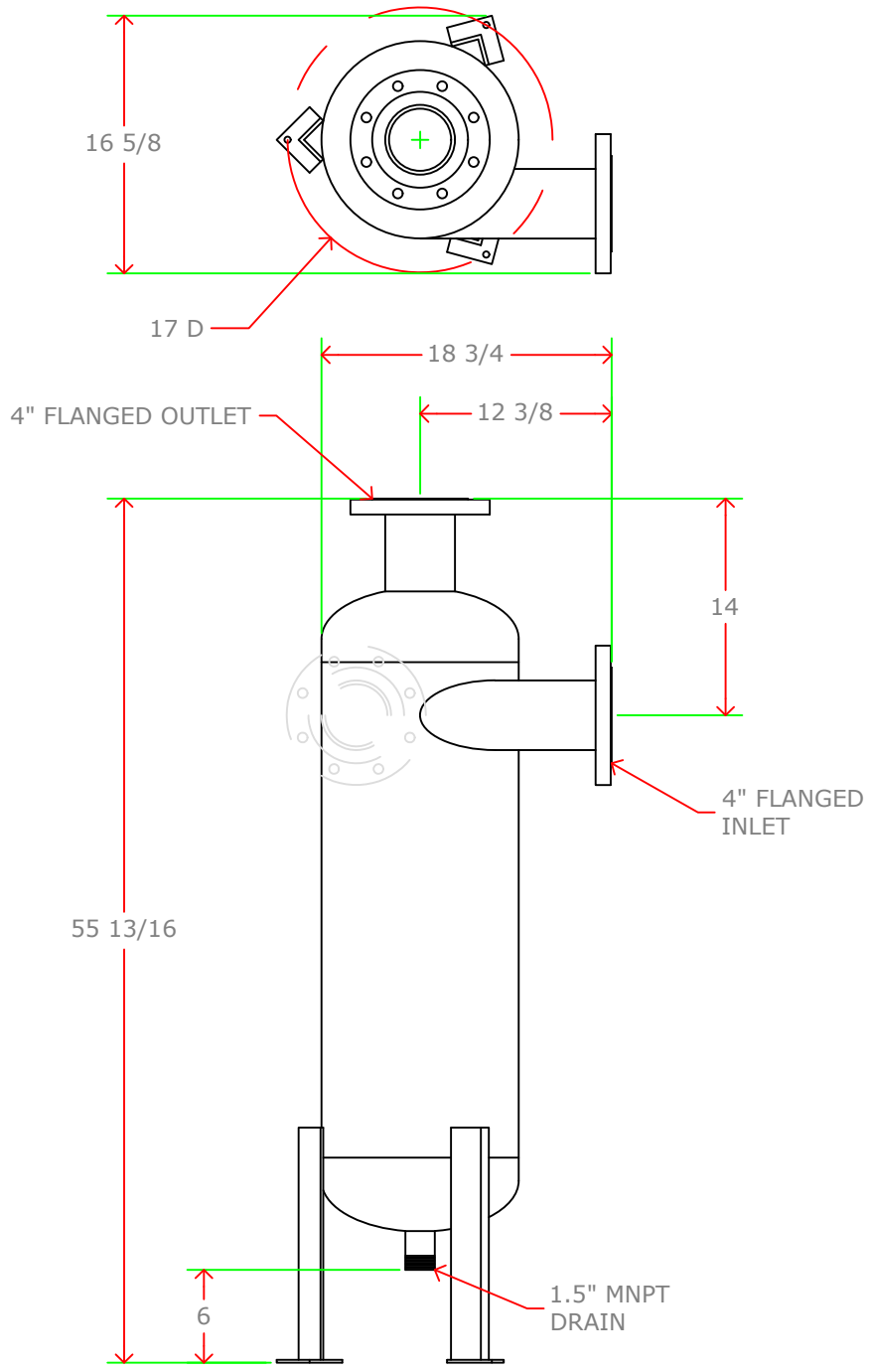
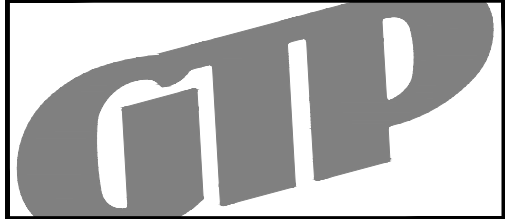

**MATERIALS OF CONSTRUCTION:**  
**CARBON STEEL**

<b>Capacity:</b>	350-610 Gallons
<b>Max Temp.:</b>	200 F
<b>Max Press.:</b>	150 PSI
<b>Weight:</b>	290 Lbs.
<b>Voltage.:</b>	x VAC x Phs x Hz
<b>FLA.:</b>	x amps

20	x	x
19	x	x
18	x	x
17	x	x
16	x	x
15	x	x
14	x	x
13	x	x
12	x	x
11	x	x
10	x	x
9	x	x
8	x	x
7	x	x
6	x	x
5	x	x
4	x	x
3	x	x
2	x	x
1	x	x

#	PART	DESCRIPTION
F	x	xx/xx/xx
E	x	xx/xx/xx
D	x	xx/xx/xx
C	x	xx/xx/xx
B	x	xx/xx/xx

REV	DESCRIPTION	DATE
-----	-------------	------

General Treatment Products, Inc.  
 PO Box 8697, Brea, CA 92822  
 Phone: 714) 257-9165 <http://www.gtpcompany.com>  
 Fax: 714) 257-9215 [customerservice@gtpcompany.com](mailto:customerservice@gtpcompany.com)

Date: 1/1/14 Scale: NTS Rev.: A

Description:  
**4" 350-610GPM FLANGED SEPARATOR**

Model:  
**SFX-0400**

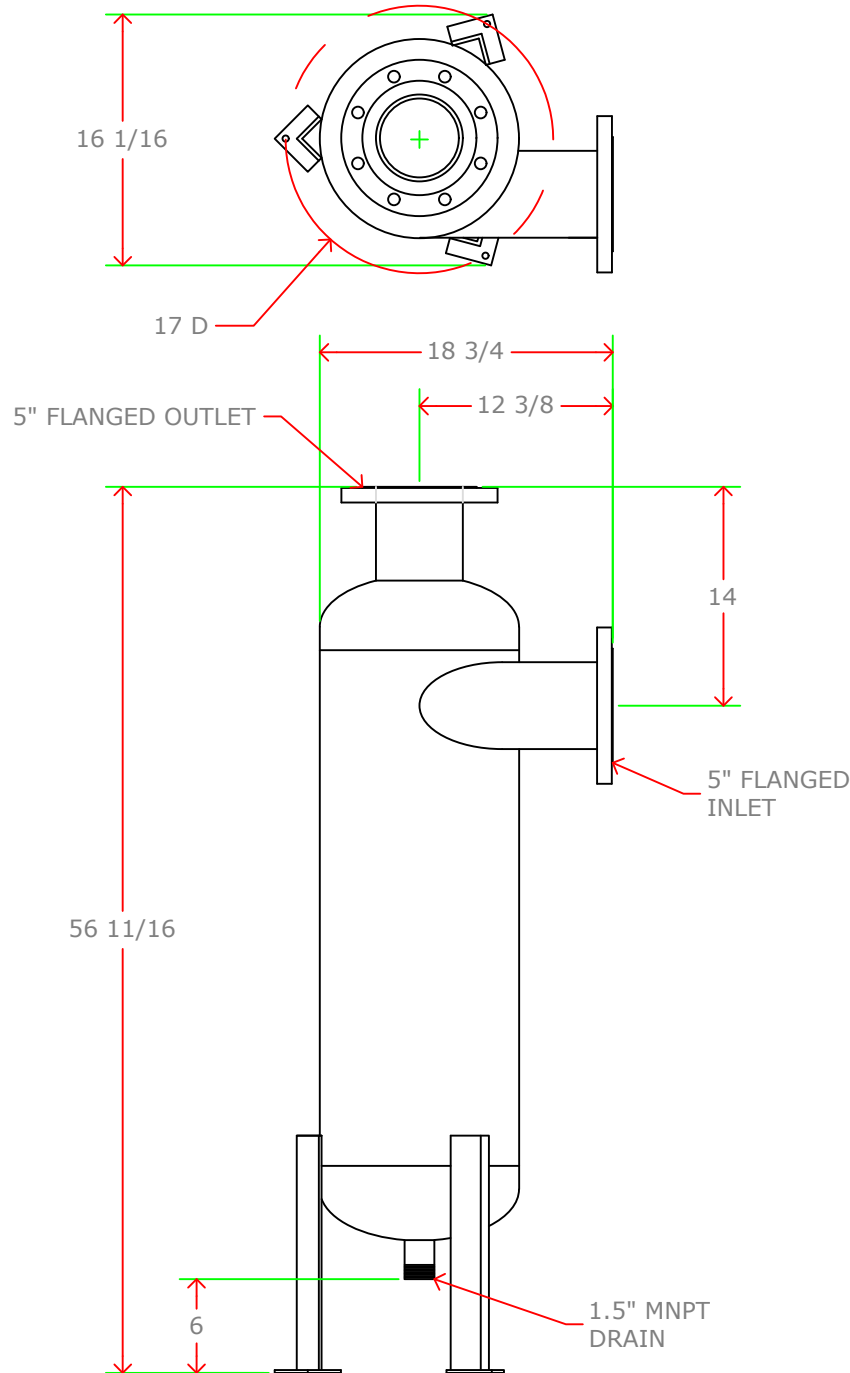
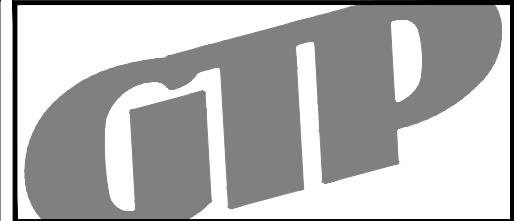

**MATERIALS OF CONSTRUCTION:**  
**CARBON STEEL**

<b>Capacity:</b>	550-960 Gallons
<b>Max Temp.:</b>	200 F
<b>Max Press.:</b>	150 PSI
<b>Weight:</b>	330 Lbs.
<b>Voltage.:</b>	x VAC x Phs x Hz
<b>FLA.:</b>	x amps

20	x	x
19	x	x
18	x	x
17	x	x
16	x	x
15	x	x
14	x	x
13	x	x
12	x	x
11	x	x
10	x	x
9	x	x
8	x	x
7	x	x
6	x	x
5	x	x
4	x	x
3	x	x
2	x	x
1	x	x

#	PART	DESCRIPTION
F	x	xx/xx/xx
E	x	xx/xx/xx
D	x	xx/xx/xx
C	x	xx/xx/xx
B	x	xx/xx/xx

REV	DESCRIPTION	DATE
-----	-------------	------

General Treatment Products, Inc.  
 PO Box 8697, Brea, CA 92822  
 Phone: 714) 257-9165 <http://www.gtpcompany.com>  
 Fax: 714) 257-9215 [customerservice@gtpcompany.com](mailto:customerservice@gtpcompany.com)

Date: 1/1/14 Scale: NTS Rev.: A

Description:  
**5" 550-960GPM FLANGED SEPARATOR**

Model:  
**SFX-0500**

NOTICE: This drawing and its contents are for the specific use of GTP customers only. It is not to be duplicated or copied without expressed written consent or General Treatment Products, Inc. We reserve the right to modify this drawing without notice.

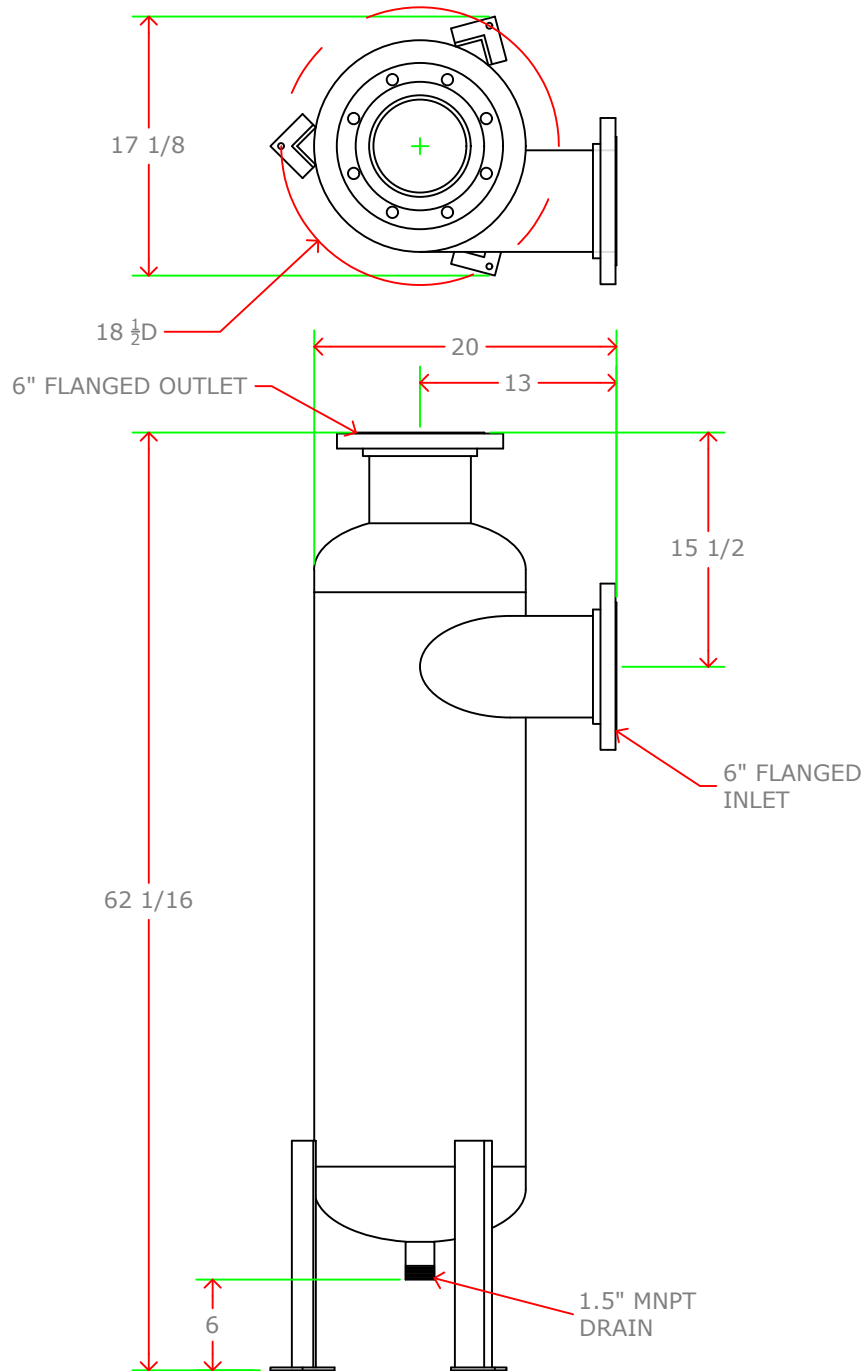
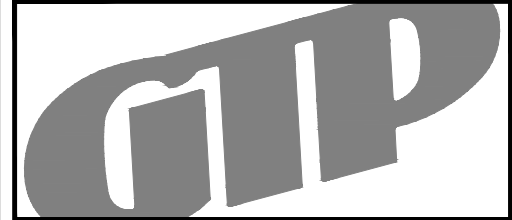

**MATERIALS OF CONSTRUCTION:**  
CARBON STEEL

**Capacity:** 800-1390 Gallons

**Max Temp.:** 200 F

**Max Press.:** 150 PSI

**Weight:** 330 Lbs.

**Voltage.:** x VAC x Phs x Hz

**FLA.:** x amps

20	x	x
19	x	x
18	x	x
17	x	x
16	x	x
15	x	x
14	x	x
13	x	x
12	x	x
11	x	x
10	x	x
9	x	x
8	x	x
7	x	x
6	x	x
5	x	x
4	x	x
3	x	x
2	x	x
1	x	x

#	PART	DESCRIPTION
F	x	xx/xx/xx
E	x	xx/xx/xx
D	x	xx/xx/xx
C	x	xx/xx/xx
B	x	xx/xx/xx

REV DESCRIPTION DATE

General Treatment Products, Inc.  
PO Box 8697, Brea, CA 92822  
Phone: 714) 257-9165 <http://www.gtpcompany.com>  
Fax: 714) 257-9215 [customerservice@gtpcompany.com](mailto:customerservice@gtpcompany.com)

Date: 1/1/14 Scale: NTS Rev.: A

Description:  
6" 800-1390GPM FLANGED SEPARATOR

Model:  
SFX-0600

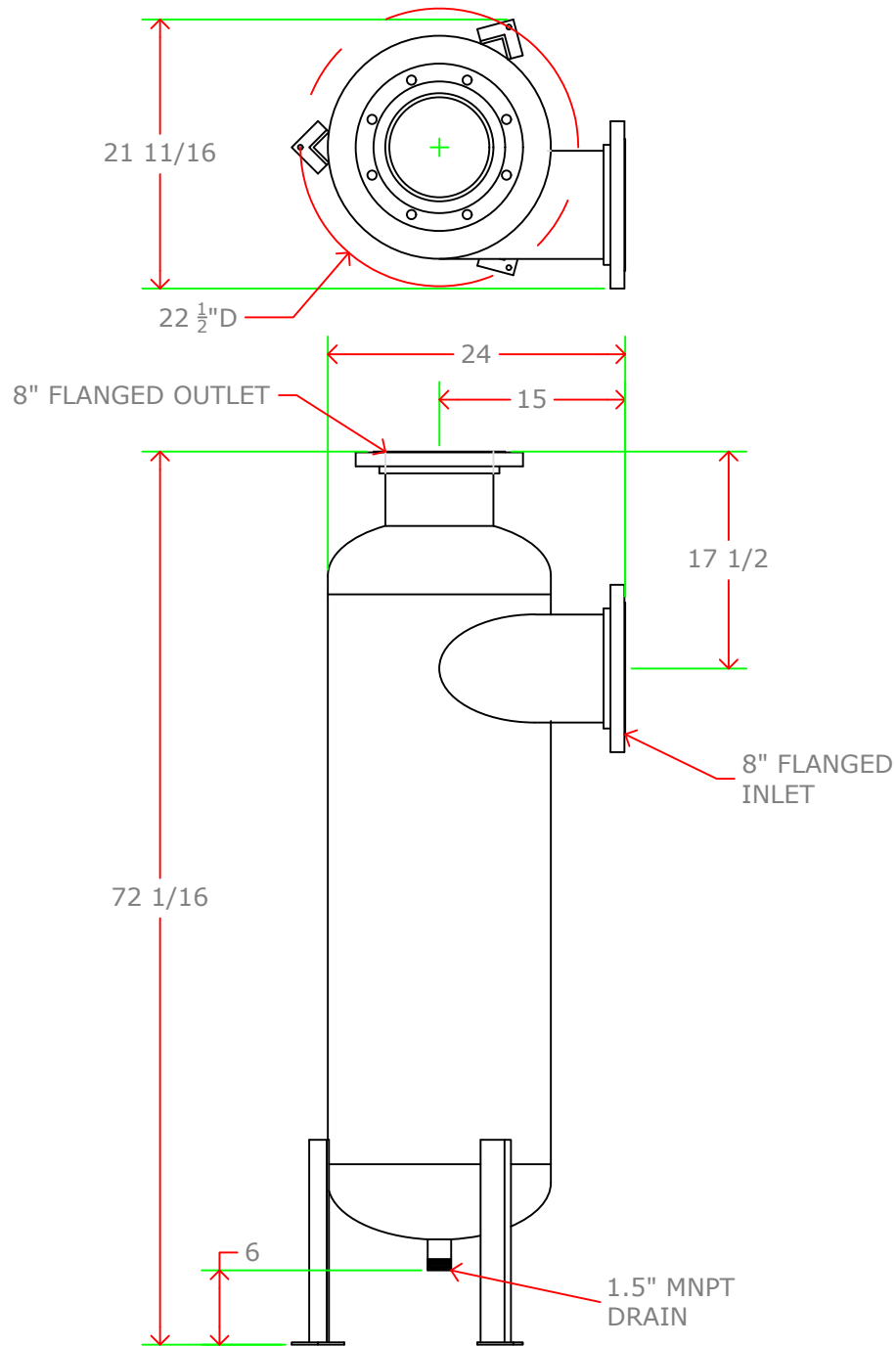
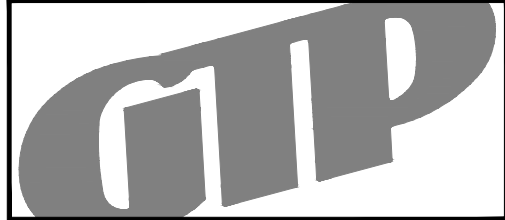

**MATERIALS OF CONSTRUCTION:**  
CARBON STEEL

<b>Capacity:</b>	1380-2400 Gallons
<b>Max Temp.:</b>	200 F
<b>Max Press.:</b>	150 PSI
<b>Weight:</b>	480 Lbs.
<b>Voltage.:</b>	x VAC x Phs x Hz
<b>FLA.:</b>	x amps

20	x	x
19	x	x
18	x	x
17	x	x
16	x	x
15	x	x
14	x	x
13	x	x
12	x	x
11	x	x
10	x	x
9	x	x
8	x	x
7	x	x
6	x	x
5	x	x
4	x	x
3	x	x
2	x	x
1	x	x

#	PART	DESCRIPTION
F	x	xx/xx/xx
E	x	xx/xx/xx
D	x	xx/xx/xx
C	x	xx/xx/xx
B	x	xx/xx/xx

REV	DESCRIPTION	DATE
-----	-------------	------

General Treatment Products, Inc.  
 PO Box 8697, Brea, CA 92822  
 Phone: 714) 257-9165 <http://www.gtpcompany.com>  
 Fax: 714) 257-9215 [customerservice@gtpcompany.com](mailto:customerservice@gtpcompany.com)

Date: 1/1/14 Scale: NTS Rev.: A

Description:  
8" 1380-2400GPM FLANGED SEPARATOR

Model:  
SFX-0800

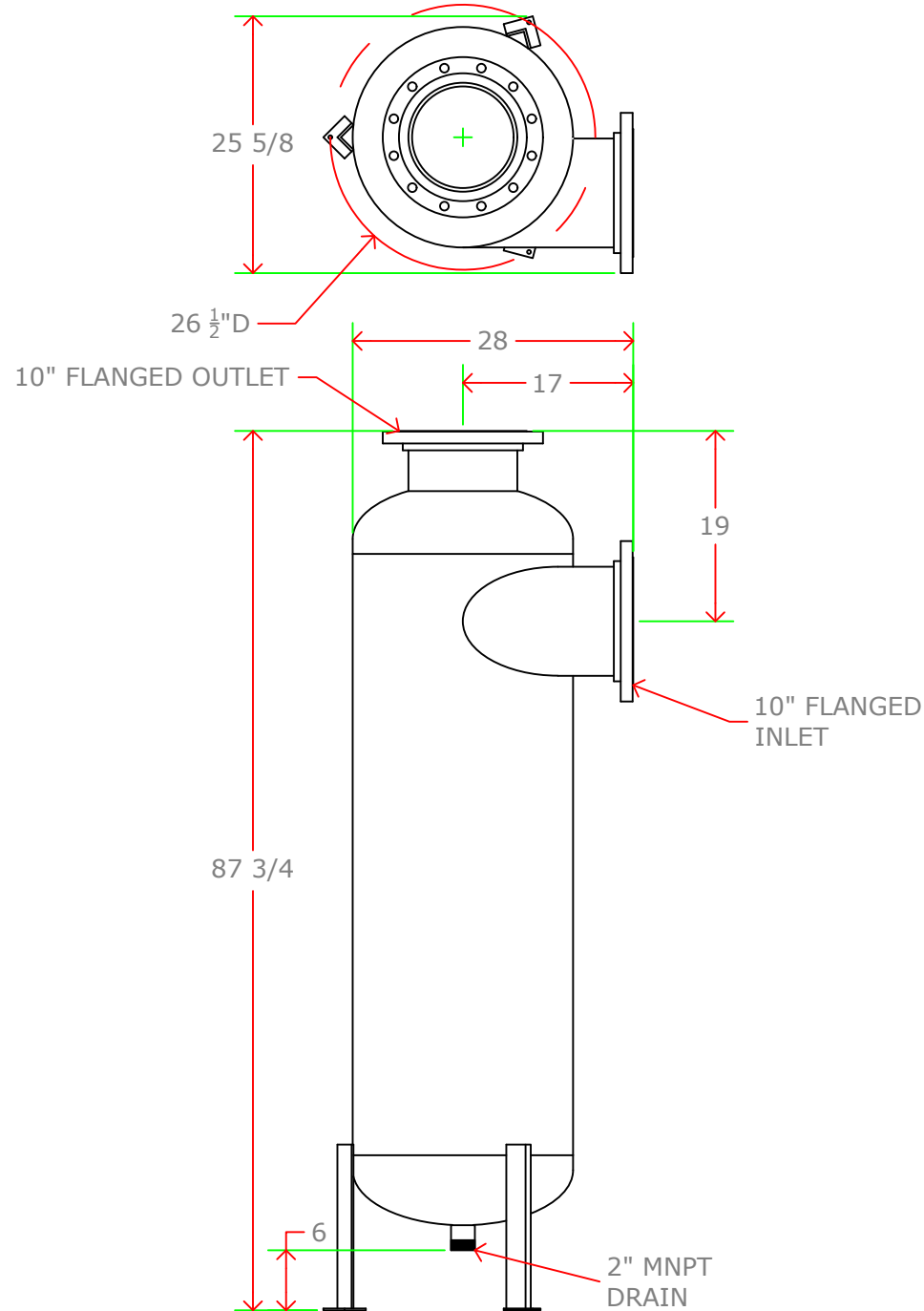
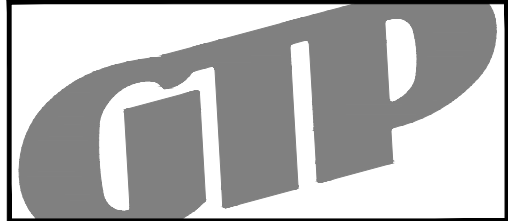

**MATERIALS OF CONSTRUCTION:**  
CARBON STEEL

<b>Capacity:</b>	2175-3780	Gallons				
<b>Max Temp.:</b>	200	F				
<b>Max Press.:</b>	150	PSI				
<b>Weight:</b>	575	Lbs.				
<b>Voltage.:</b>	x	VAC	x	Phs	x	Hz
<b>FLA.:</b>	x	amps				

20	x	x
19	x	x
18	x	x
17	x	x
16	x	x
15	x	x
14	x	x
13	x	x
12	x	x
11	x	x
10	x	x
9	x	x
8	x	x
7	x	x
6	x	x
5	x	x
4	x	x
3	x	x
2	x	x
1	x	x

#	PART	DESCRIPTION	DATE
F	x	xx/xx/xx	xx/xx/xx
E	x	xx/xx/xx	xx/xx/xx
D	x	xx/xx/xx	xx/xx/xx
C	x	xx/xx/xx	xx/xx/xx
B	x	xx/xx/xx	xx/xx/xx

**General Treatment Products, Inc.**  
 PO Box 8697, Brea, CA 92822  
 Phone: 714) 257-9165      <http://www.gtpcompany.com>  
 Fax: 714) 257-9215      [customerservice@gtpcompany.com](mailto:customerservice@gtpcompany.com)

Date: 1/1/14      Scale: NTS      Rev.: A

Description:  
10" 2175-3780GPM FLANGED SEPARATOR  
Model:  
SFX-1000

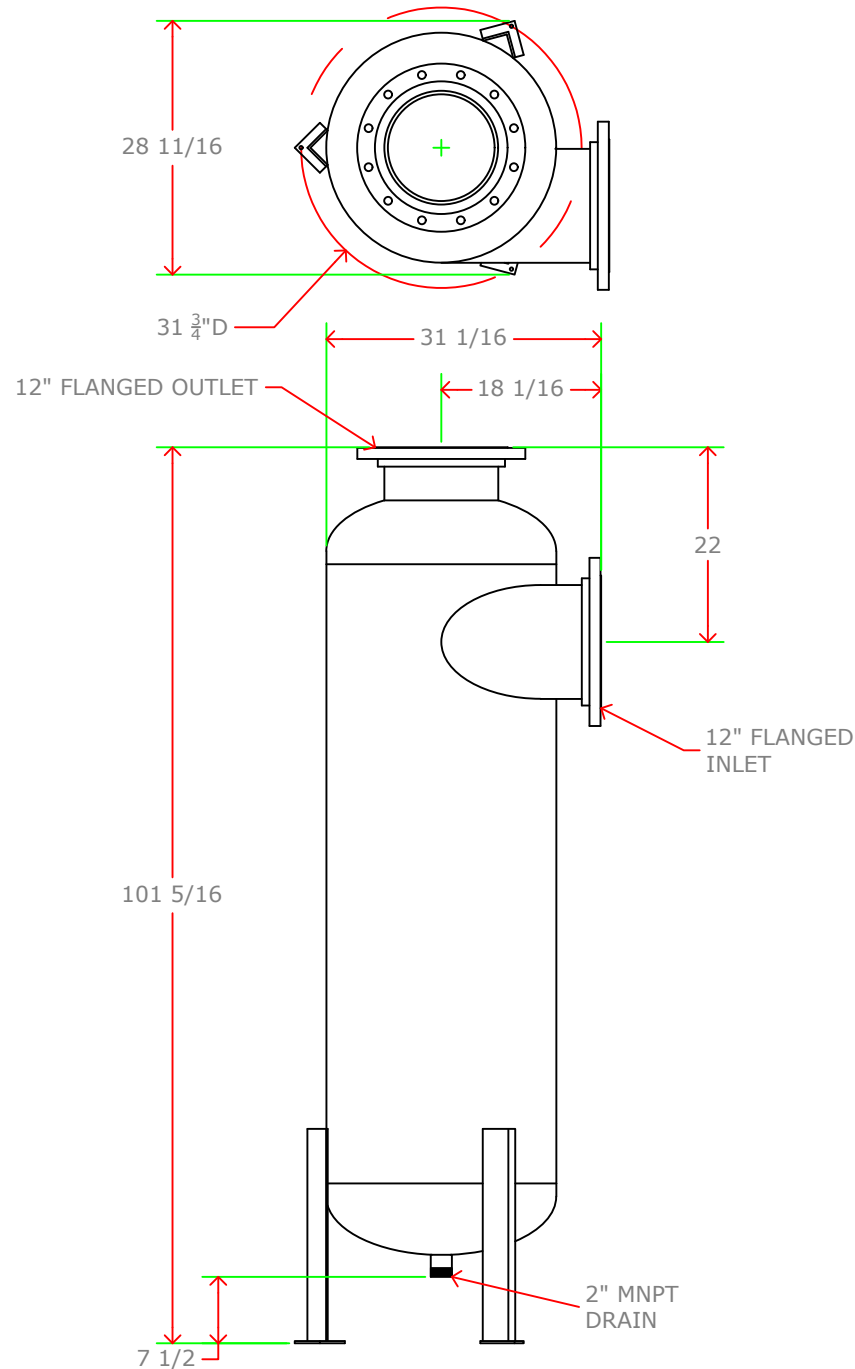
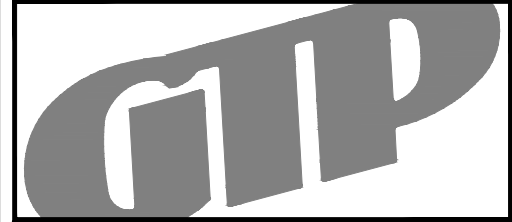

**MATERIALS OF CONSTRUCTION:**  
**CARBON STEEL**

**Capacity:** 2910-5050 Gallons  
**Max Temp.:** 200 F  
**Max Press.:** 150 PSI  
**Weight:** 855 Lbs.  
**Voltage.:** x VAC x Phs x Hz  
**FLA.:** x amps

20	x	x
19	x	x
18	x	x
17	x	x
16	x	x
15	x	x
14	x	x
13	x	x
12	x	x
11	x	x
10	x	x
9	x	x
8	x	x
7	x	x
6	x	x
5	x	x
4	x	x
3	x	x
2	x	x
1	x	x

#	PART	DESCRIPTION
F	x	xx/xx/xx
E	x	xx/xx/xx
D	x	xx/xx/xx
C	x	xx/xx/xx
B	x	xx/xx/xx

REV	DESCRIPTION	DATE
-----	-------------	------

General Treatment Products, Inc.  
 PO Box 8697, Brea, CA 92822  
 Phone: 714) 257-9165 <http://www.gtpcompany.com>  
 Fax: 714) 257-9215 [customerservice@gtpcompany.com](mailto:customerservice@gtpcompany.com)

Date: 1/1/14 Scale: NTS Rev.: A

Description:  
**12" 2910-5050GPM FLANGED SEPARATOR**

Model:  
**SFX-1200**

NOTICE: This drawing and its contents are for the specific use of GTP customers only. It is not to be duplicated or copied without expressed written consent of General Treatment Products, Inc. We reserve the right to modify this drawing without notice.

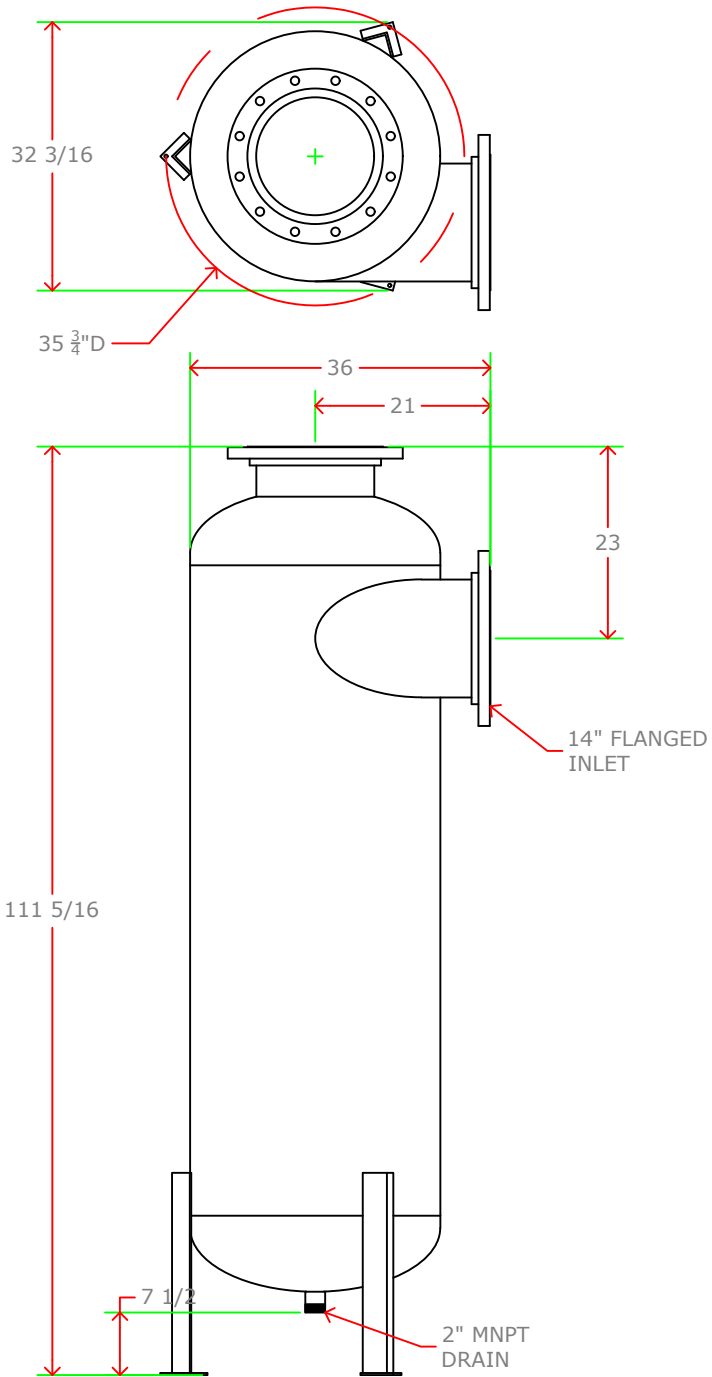
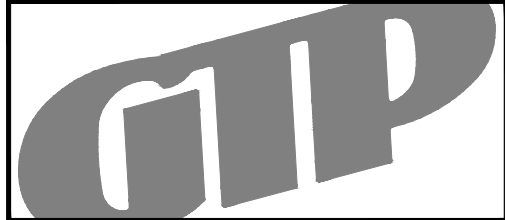

**MATERIALS OF CONSTRUCTION:**  
CARBON STEEL

<b>Capacity:</b>	3810-6600	Gallons				
<b>Max Temp.:</b>	200	F				
<b>Max Press.:</b>	150	PSI				
<b>Weight:</b>	1390	Lbs.				
<b>Voltage.:</b>	x	VAC	x	Phs	x	Hz
<b>FLA.:</b>	x	amps				

20	x	x
19	x	x
18	x	x
17	x	x
16	x	x
15	x	x
14	x	x
13	x	x
12	x	x
11	x	x
10	x	x
9	x	x
8	x	x
7	x	x
6	x	x
5	x	x
4	x	x
3	x	x
2	x	x
1	x	x

#	PART	DESCRIPTION	DATE
F	x		xx/xx/xx
E	x		xx/xx/xx
D	x		xx/xx/xx
C	x		xx/xx/xx
B	x		xx/xx/xx

REV DESCRIPTION DATE

General Treatment Products, Inc.  
PO Box 8697, Brea, CA 92822  
Phone: 714) 257-9165 <http://www.gtpcompany.com>  
Fax: 714) 257-9215 [customerservice@gtpcompany.com](mailto:customerservice@gtpcompany.com)

Date: 1/1/14 Scale: NTS Rev.: A

Description: 14" 3810-6600GPM FLANGED SEPARATOR

Model: SFX-1400

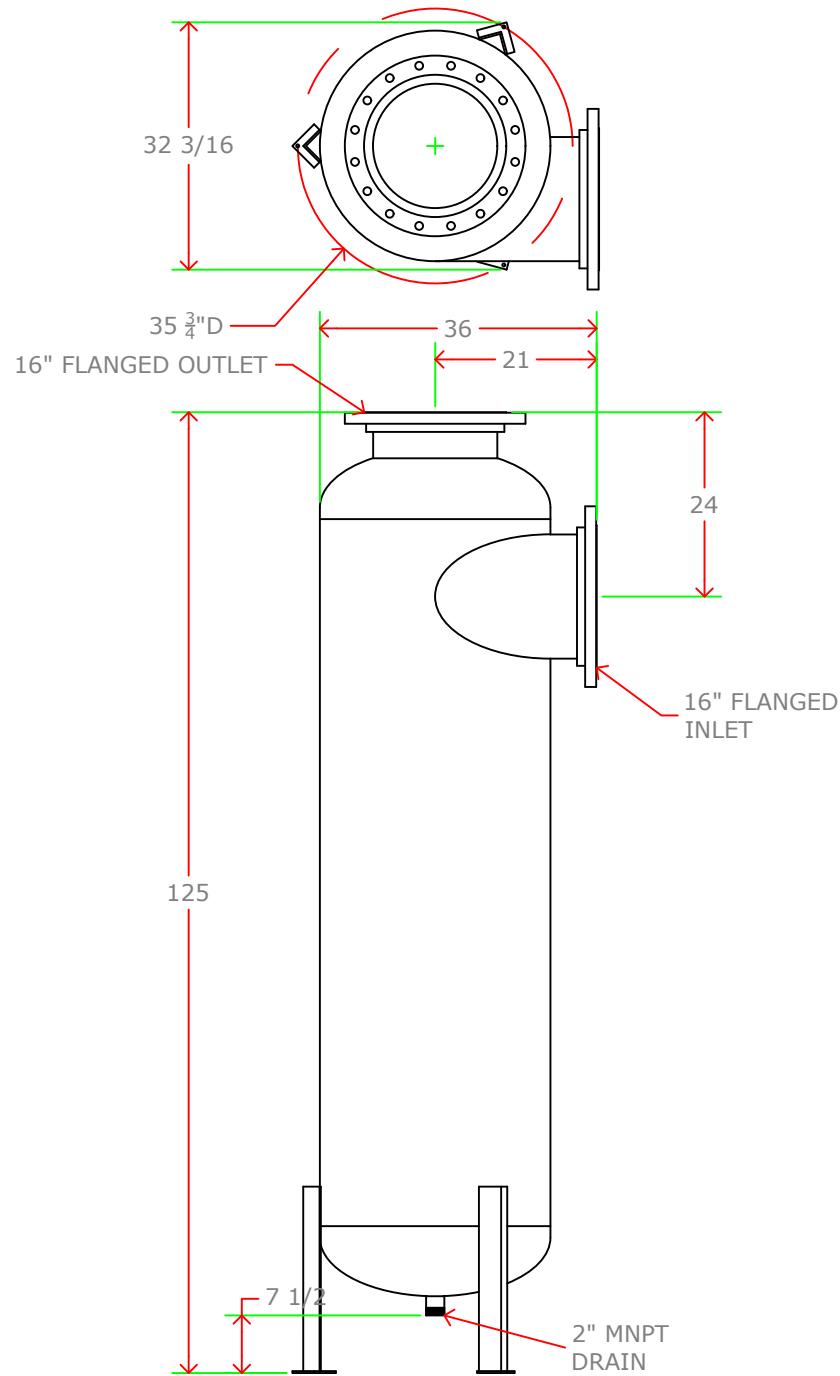
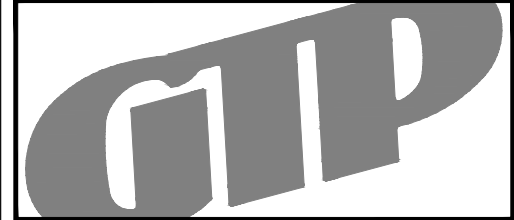

**MATERIALS OF CONSTRUCTION:**  
CARBON STEEL

**Capacity:** 5050-8760 Gallons  
**Max Temp.:** 200 F  
**Max Press.:** 150 PSI  
**Weight:** 1650 Lbs.  
**Voltage.:** x VAC x Phs x Hz  
**FLA.:** x amps

20	x	x
19	x	x
18	x	x
17	x	x
16	x	x
15	x	x
14	x	x
13	x	x
12	x	x
11	x	x
10	x	x
9	x	x
8	x	x
7	x	x
6	x	x
5	x	x
4	x	x
3	x	x
2	x	x
1	x	x

#	PART	DESCRIPTION
F	x	xx/xx/xx
E	x	xx/xx/xx
D	x	xx/xx/xx
C	x	xx/xx/xx
B	x	xx/xx/xx

REV	DESCRIPTION	DATE
-----	-------------	------

General Treatment Products, Inc.  
 PO Box 8697, Brea, CA 92822  
 Phone: (714) 257-9165 <http://www.gtpcompany.com>  
 Fax: (714) 257-9215 [customerservice@gtpcompany.com](mailto:customerservice@gtpcompany.com)

Date: 1/1/14 Scale: NTS Rev.: A

Description:  
16" 5050-8760GPM FLANGED SEPARATOR

Model:  
SFX-1600



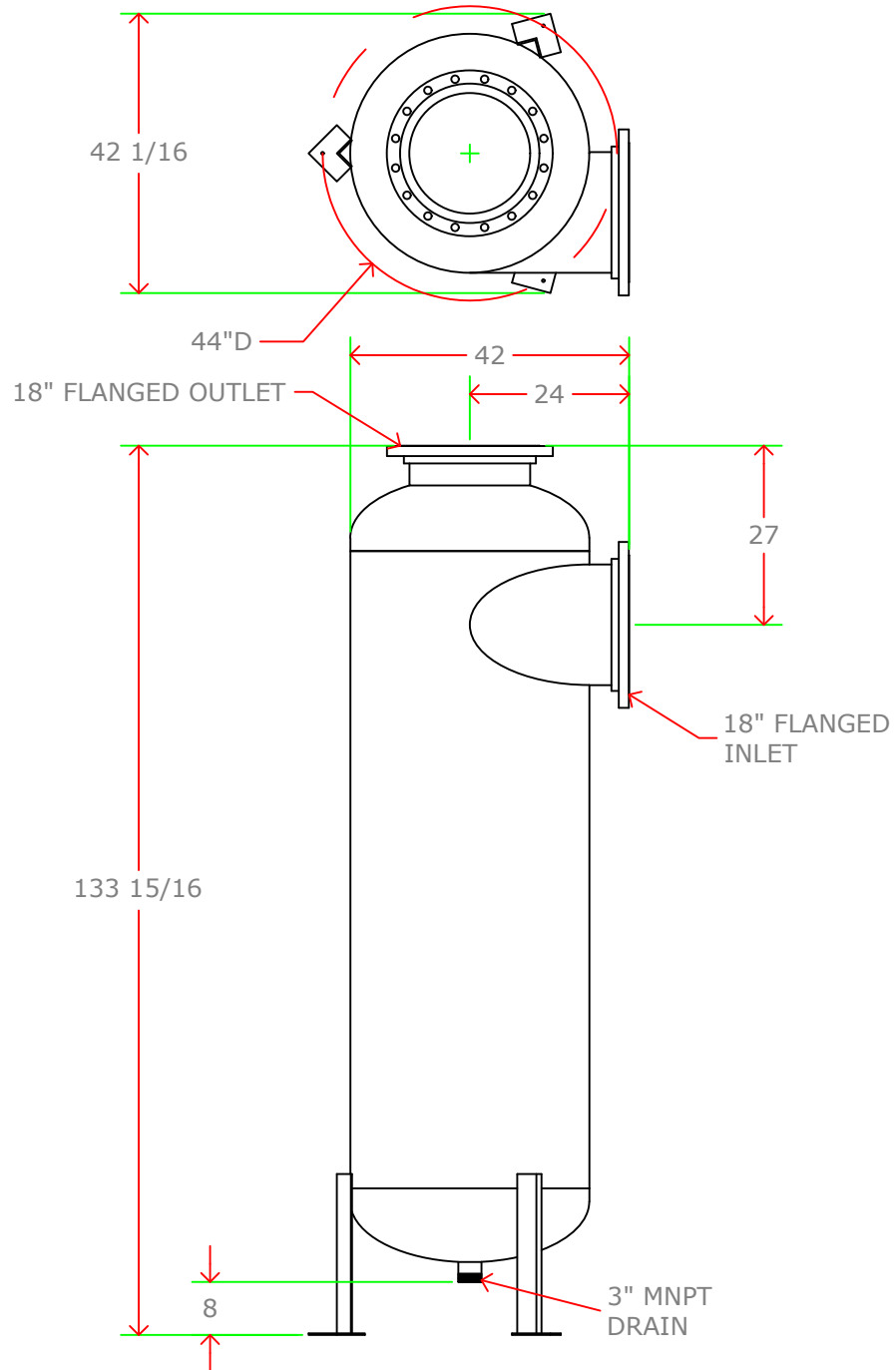
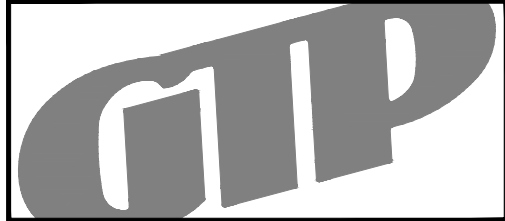

**MATERIALS OF CONSTRUCTION:**  
CARBON STEEL

<b>Capacity:</b>	6500-11200 Gallons					
<b>Max Temp.:</b>	200 F					
<b>Max Press.:</b>	150 PSI					
<b>Weight:</b>	2150 Lbs.					
<b>Voltage.:</b>	x	VAC	x	Phs	x	Hz
<b>FLA.:</b>	x	amps				
20	x		x			
19	x		x			
18	x		x			
17	x		x			
16	x		x			
15	x		x			
14	x		x			
13	x		x			
12	x		x			
11	x		x			
10	x		x			
9	x		x			
8	x		x			
7	x		x			
6	x		x			
5	x		x			
4	x		x			
3	x		x			
2	x		x			
1	x		x			
#	PART	DESCRIPTION				
F	x	xx/xx/xx				
E	x	xx/xx/xx				
D	x	xx/xx/xx				
C	x	xx/xx/xx				
B	x	xx/xx/xx				
REV	DESCRIPTION	DATE				

General Treatment Products, Inc.  
PO Box 8697, Brea, CA 92822  
Phone: 714) 257-9165 <http://www.gtpcompany.com>  
Fax: 714) 257-9215 [customerservice@gtpcompany.com](mailto:customerservice@gtpcompany.com)

Date: 1/1/14 Scale: NTS Rev.: A  
Description:  
18" 6500-11200GPM FLANGED SEPARATOR  
Model:  
SFX-1800

NOTICE: This drawing and its contents are for the specific use of GTP customers only. It is not to be duplicated or copied without expressed written consent of General Treatment Products, Inc. We reserve the right to modify this drawing without notice.

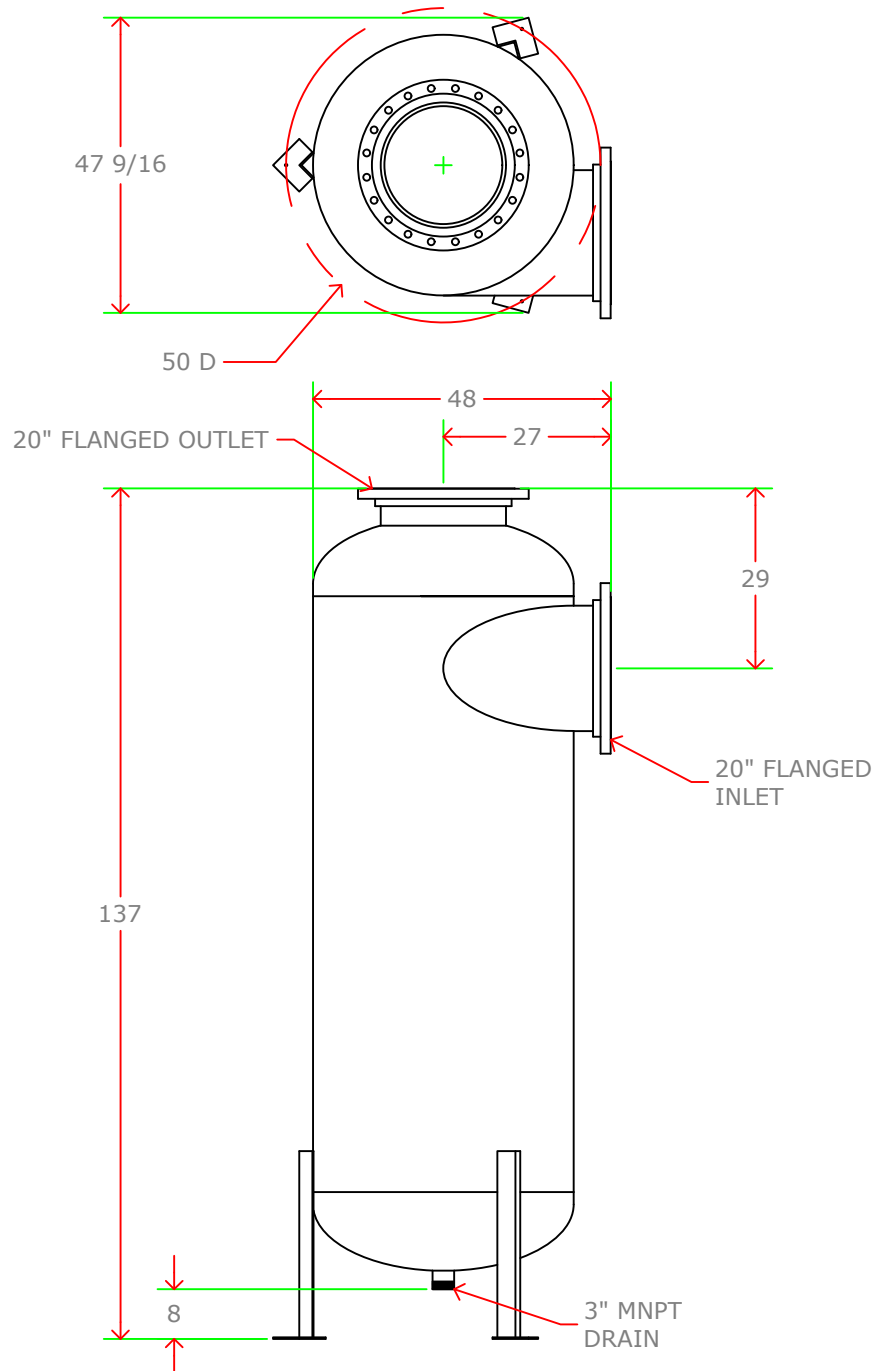

**MATERIALS OF CONSTRUCTION:**  
CARBON STEEL

<b>Capacity:</b>	8050-13950 Gallons
<b>Max Temp.:</b>	200 F
<b>Max Press.:</b>	150 PSI
<b>Weight:</b>	2652 Lbs.
<b>Voltage.:</b>	x VAC x Phs x Hz
<b>FLA.:</b>	x amps

20	x	x
19	x	x
18	x	x
17	x	x
16	x	x
15	x	x
14	x	x
13	x	x
12	x	x
11	x	x
10	x	x
9	x	x
8	x	x
7	x	x
6	x	x
5	x	x
4	x	x
3	x	x
2	x	x
1	x	x

#	PART	DESCRIPTION
F	x	xx/xx/xx
E	x	xx/xx/xx
D	x	xx/xx/xx
C	x	xx/xx/xx
B	x	xx/xx/xx

REV	DESCRIPTION	DATE
-----	-------------	------

General Treatment Products, Inc.  
 PO Box 8697, Brea, CA 92822  
 Phone: 714) 257-9165 <http://www.gtpcompany.com>  
 Fax: 714) 257-9215 [customerservice@gtpcompany.com](mailto:customerservice@gtpcompany.com)

Date: 1/1/14 Scale: NTS Rev.: A

Description:  
20" 8050-13950GPM FLANGED SEPARATOR

Model:  
SFX-2000