

**MATERIALS OF CONSTRUCTION:**  
POLYETHYLENE, FIBERGLASS

**Capacity:** 30 Gallons  
**Max Temp.:** 76 F  
**Max Press.:** N/A PSI  
**Weight:** 45 Lbs.

20	x	x
19	x	x
18	x	x
17	x	x
16	x	x
15	x	x
14	x	x
13	x	x
12	x	x
11	x	x
10	x	x
9	x	x
8	x	x
7	x	x
6	x	x
5	x	x
4	x	x
3	x	x
2	x	x
1	x	x

#	PART	DESCRIPTION
F	x	xx/xx/xx
E	x	xx/xx/xx
D	x	xx/xx/xx
C	x	xx/xx/xx
B	x	xx/xx/xx

REV	DESCRIPTION	DATE
-----	-------------	------

General Treatment Products, Inc.  
 PO Box 8697, Brea, CA 92822  
 Phone: 714) 257-9165 <http://www.gtpcompany.com>  
 Fax: 714) 257-9215 [customerservice@gtpcompany.com](mailto:customerservice@gtpcompany.com)

Date: 11/01/16 Scale: NTS Rev.: A

Description:  
SPILL PALLET 36X36

Model:  
SP3636

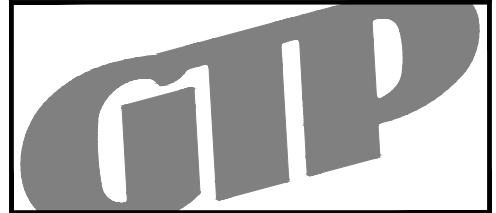
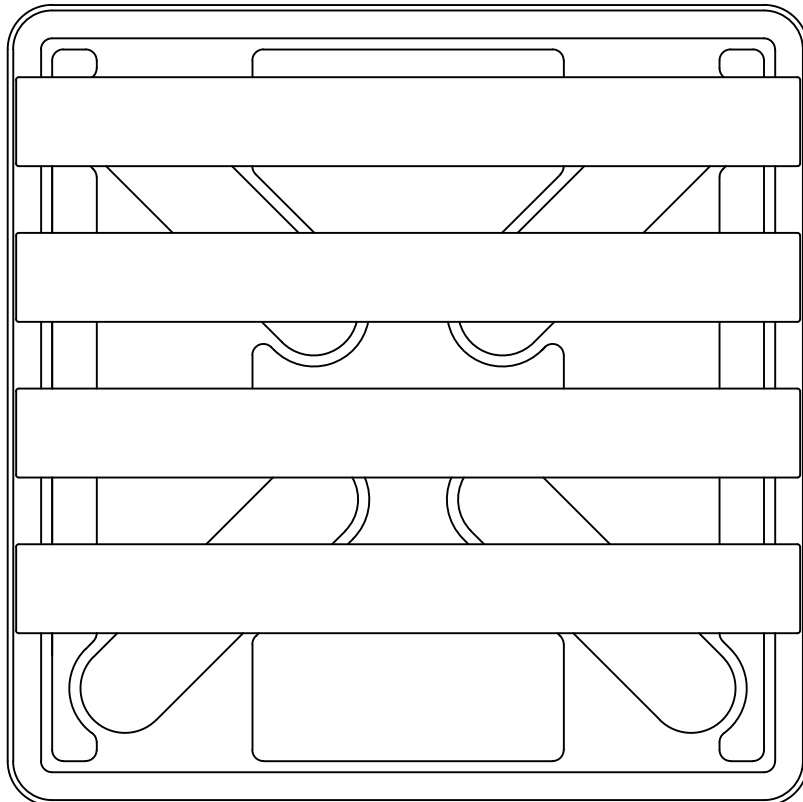
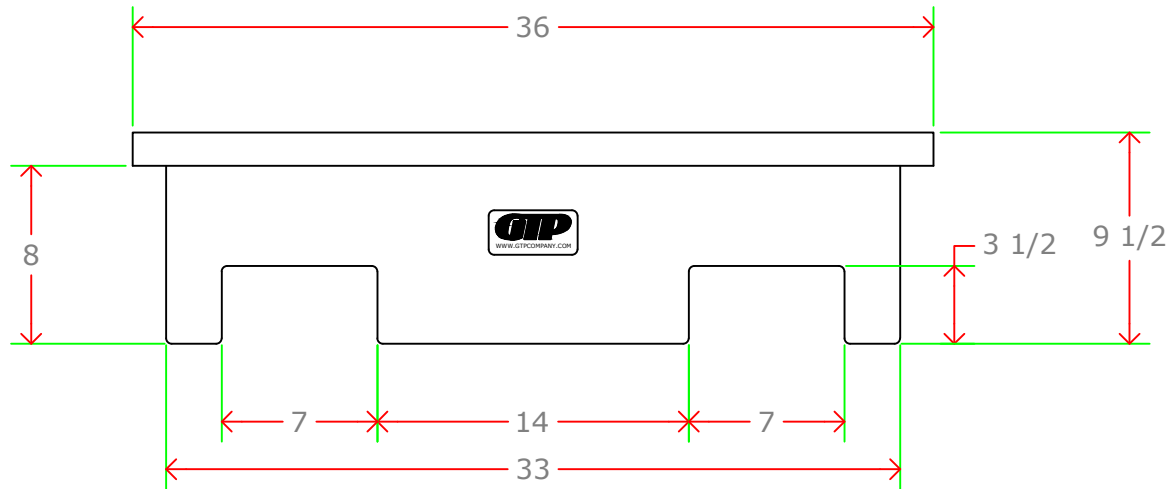

**MATERIALS OF CONSTRUCTION:**  
POLYETHYLENE, FIBERGLASS

**Capacity:** 30 Gallons  
**Max Temp.:** 76 F  
**Max Press.:** N/A PSI  
**Weight:** 45 Lbs.

20	x	x
19	x	x
18	x	x
17	x	x
16	x	x
15	x	x
14	x	x
13	x	x
12	x	x
11	x	x
10	x	x
9	x	x
8	x	x
7	x	x
6	x	x
5	x	x
4	x	x
3	x	x
2	x	x
1	x	x

#	PART	DESCRIPTION
F	x	xx/xx/xx
E	x	xx/xx/xx
D	x	xx/xx/xx
C	x	xx/xx/xx
B	x	xx/xx/xx

REV	DESCRIPTION	DATE
-----	-------------	------

General Treatment Products, Inc.  
 PO Box 8697, Brea, CA 92822  
 Phone: 714) 257-9165 <http://www.gtpcompany.com>  
 Fax: 714) 257-9215 [customerservice@gtpcompany.com](mailto:customerservice@gtpcompany.com)

Date: 11/01/16 Scale: NTS Rev.: A

Description:  
SPILL PALLET 36X36

Model:  
SP3636

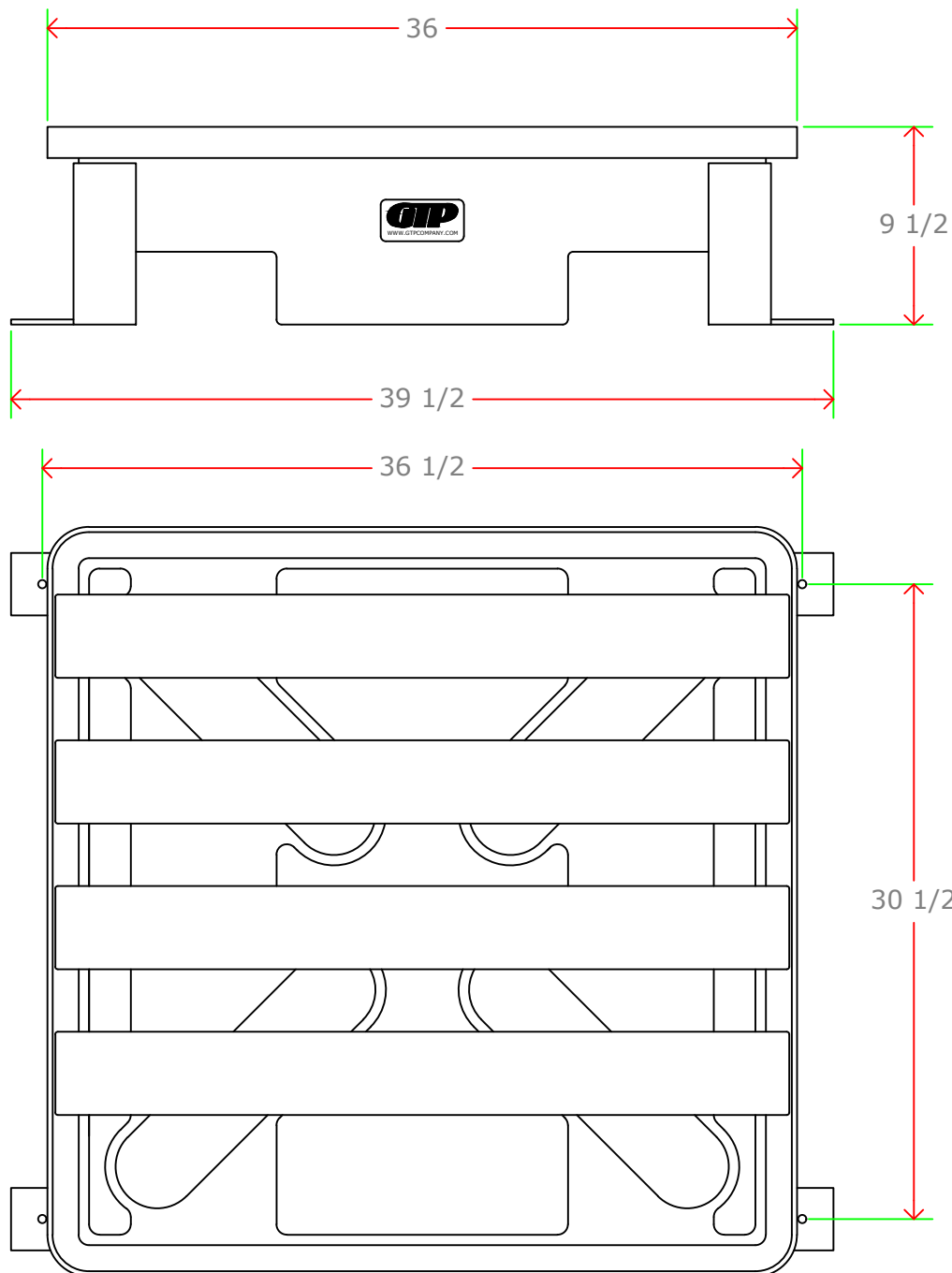

**MATERIALS OF CONSTRUCTION:**  
POLYETHYLENE, FIBERGLASS

**Capacity:** 30 Gallons

**Max Temp.:** 76 F

**Max Press.:** N/A PSI

**Weight:** 45 Lbs.

20	x	x
19	x	x
18	x	x
17	x	x
16	x	x
15	x	x
14	x	x
13	x	x
12	x	x
11	x	x
10	x	x
9	x	x
8	x	x
7	x	x
6	x	x
5	x	x
4	x	x
3	x	x
2	x	x
1	x	x

#	PART	DESCRIPTION
F	x	xx/xx/xx
E	x	xx/xx/xx
D	x	xx/xx/xx
C	x	xx/xx/xx
B	x	xx/xx/xx
REV	DESCRIPTION	DATE

General Treatment Products, Inc.  
PO Box 8697, Brea, CA 92822  
Phone: 714) 257-9165 <http://www.gtpcompany.com>  
Fax: 714) 257-9215 [customerservice@gtpcompany.com](mailto:customerservice@gtpcompany.com)

Date: 11/01/16 Scale: NTS Rev.: A

Description:  
SPILL PALLET 36X36

Model:  
SP3636G-RS



**MATERIALS OF CONSTRUCTION:**  
 POLYETHYLENE (YELLOW/BLACK)  
 CAPACITY: 2000LBS

**Capacity:** 12 Gallons  
**Max Temp.:** 85 F  
**Max Press.:** N/A PSI  
**Weight:** 16 Lbs.  
**Voltage.:** x VAC x Phs x Hz  
**FLA.:** x amps

20	x	x
19	x	x
18	x	x
17	x	x
16	x	x
15	x	x
14	x	x
13	x	x
12	x	x
11	x	x
10	x	x
9	x	x
8	x	x
7	x	x
6	x	x
5	x	x
4	x	x
3	x	x
2	x	x
1	x	x

#	PART	DESCRIPTION
F	x	xx/xx/xx
E	x	xx/xx/xx
D	x	xx/xx/xx
C	x	xx/xx/xx
B	x	xx/xx/xx

REV	DESCRIPTION	DATE

General Treatment Products, Inc.  
 PO Box 8697, Brea, CA 92822  
 Phone: 714) 257-9165 <http://www.gtpcompany.com>  
 Fax: 714) 257-9215 [customerservice@gtpcompany.com](mailto:customerservice@gtpcompany.com)

Date: 6/21/13 Scale: NTS Rev.: A

Description:  
 SPILL PALLET, 1 DRUM

Model:  
 SP-1D

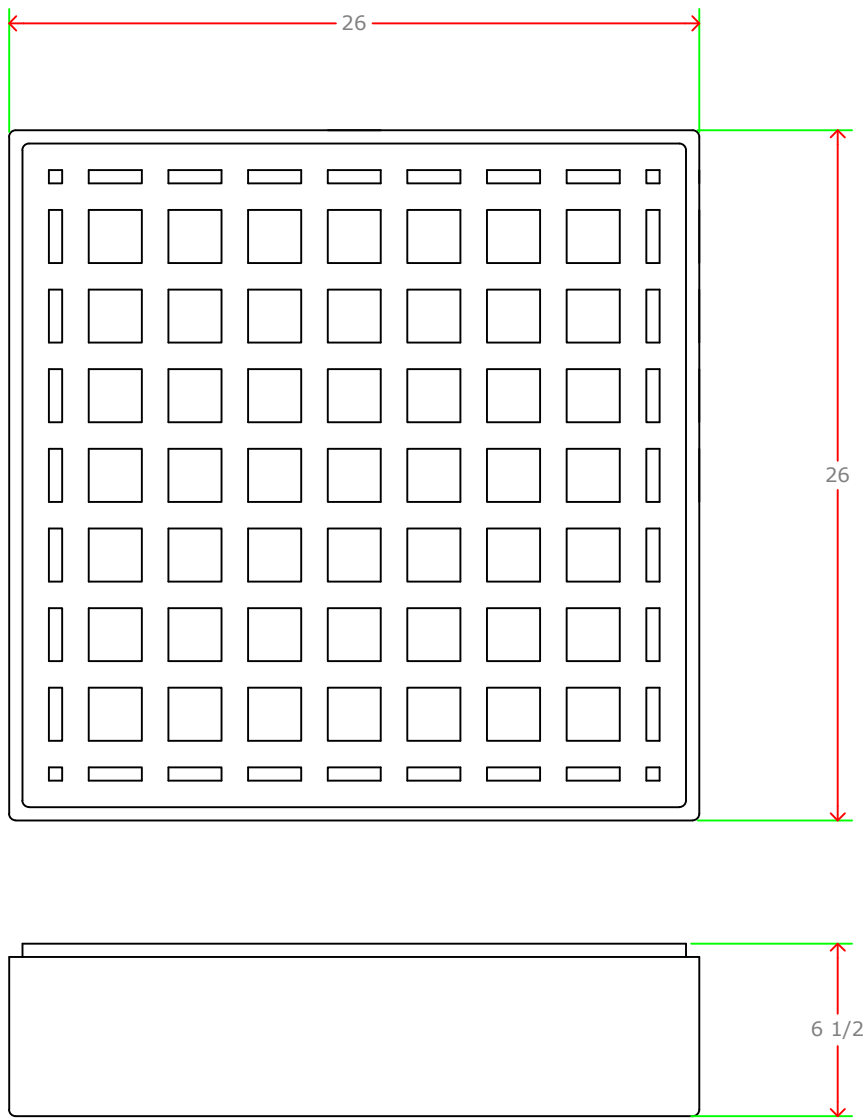

NOTICE: This drawing and its contents are for the specific use of GTP customers only. It is not to be duplicated or copied without expressed written consent of General Treatment Products, Inc. We reserve the right to modify this drawing without notice.

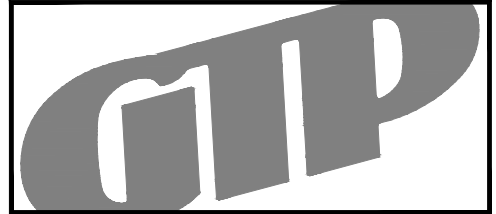

**MATERIALS OF CONSTRUCTION:**  
 POLYETHYLENE (YELLOW/BLACK)  
 CAPACITY: 5000LBS

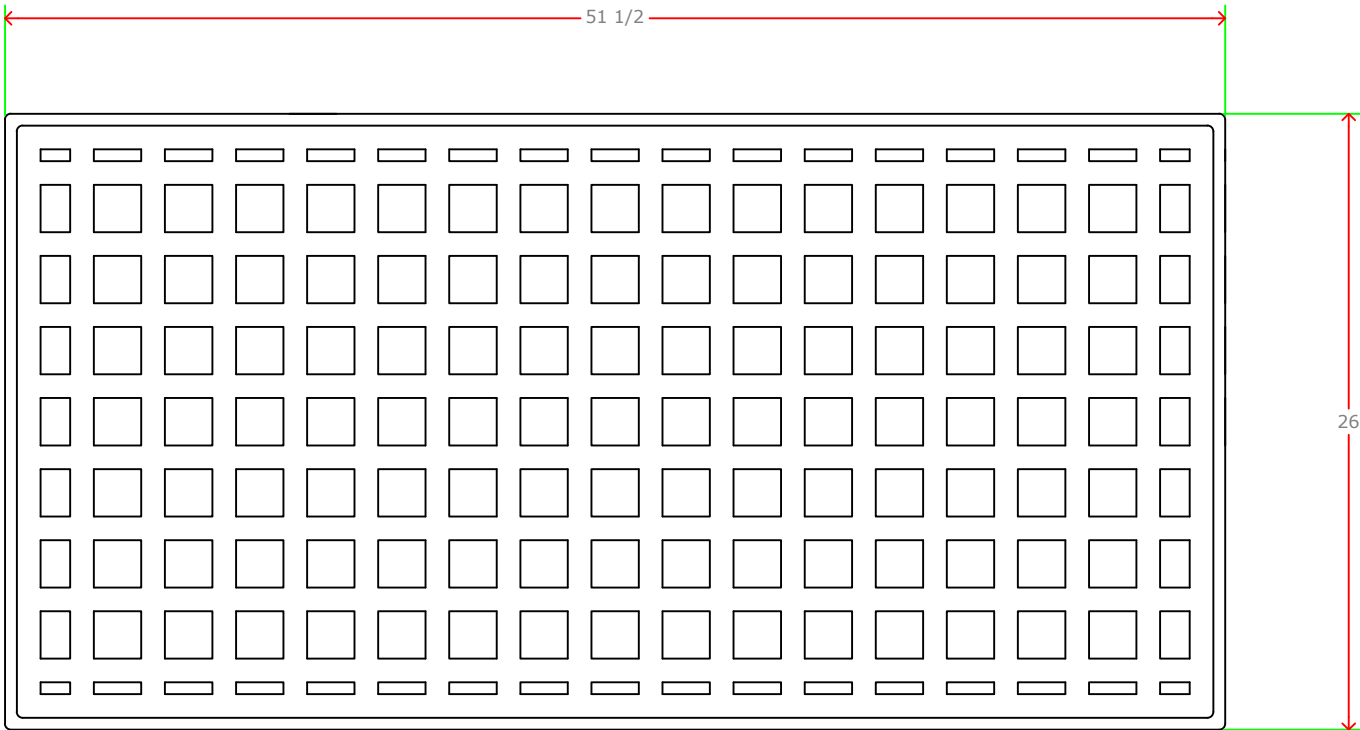

<b>Capacity:</b>	30	Gallons				
<b>Max Temp.:</b>	85	F				
<b>Max Press.:</b>	N/A	PSI				
<b>Weight:</b>	34	Lbs.				
<b>Voltage.:</b>	x	VAC	x	Phs	x	Hz
<b>FLA.:</b>	x	amps				
20	x	x				
19	x	x				
18	x	x				
17	x	x				
16	x	x				
15	x	x				
14	x	x				
13	x	x				
12	x	x				
11	x	x				
10	x	x				
9	x	x				
8	x	x				
7	x	x				
6	x	x				
5	x	x				
4	x	x				
3	x	x				
2	x	x				
1	x	x				

#	PART	DESCRIPTION
F	x	xx/xx/xx
E	x	xx/xx/xx
D	x	xx/xx/xx
C	x	xx/xx/xx
B	x	xx/xx/xx

REV	DESCRIPTION	DATE
-----	-------------	------

General Treatment Products, Inc.  
 PO Box 8697, Brea, CA 92822  
 Phone: 714) 257-9165 <http://www.gtpcompany.com>  
 Fax: 714) 257-9215 [customerservice@gtpcompany.com](mailto:customerservice@gtpcompany.com)

Date: 6/21/13 Scale: NTS Rev.: A

Description:  
 SPILL PALLET, 2 DRUM

Model:  
 SP-2D

NOTICE: This drawing and its contents are for the specific use of GTP customers only. It is not to be duplicated or copied without expressed written consent or General Treatment Products, Inc. We reserve the right to modify this drawing without notice.



**MATERIALS OF CONSTRUCTION:**  
 POLYETHYLENE (YELLOW/BLACK)  
 CAPACITY: 10000LBS

**Capacity:** 60 Gallons  
**Max Temp.:** 85 F  
**Max Press.:** N/A PSI  
**Weight:** 65 Lbs.  
**Voltage.:** x VAC x Phs x Hz  
**FLA.:** x amps

20	x	x
19	x	x
18	x	x
17	x	x
16	x	x
15	x	x
14	x	x
13	x	x
12	x	x
11	x	x
10	x	x
9	x	x
8	x	x
7	x	x
6	x	x
5	x	x
4	x	x
3	x	x
2	x	x
1	x	x

#	PART	DESCRIPTION
F	x	xx/xx/xx
E	x	xx/xx/xx
D	x	xx/xx/xx
C	x	xx/xx/xx
B	x	xx/xx/xx

REV	DESCRIPTION	DATE
-----	-------------	------

General Treatment Products, Inc.  
 PO Box 8697, Brea, CA 92822  
 Phone: 714) 257-9165 <http://www.gtpcompany.com>  
 Fax: 714) 257-9215 [customerservice@gtpcompany.com](mailto:customerservice@gtpcompany.com)

Date: 6/21/13 Scale: NTS Rev.: A

Description:  
 SPILL PALLET, 4 DRUM

Model:  
 SP-4D

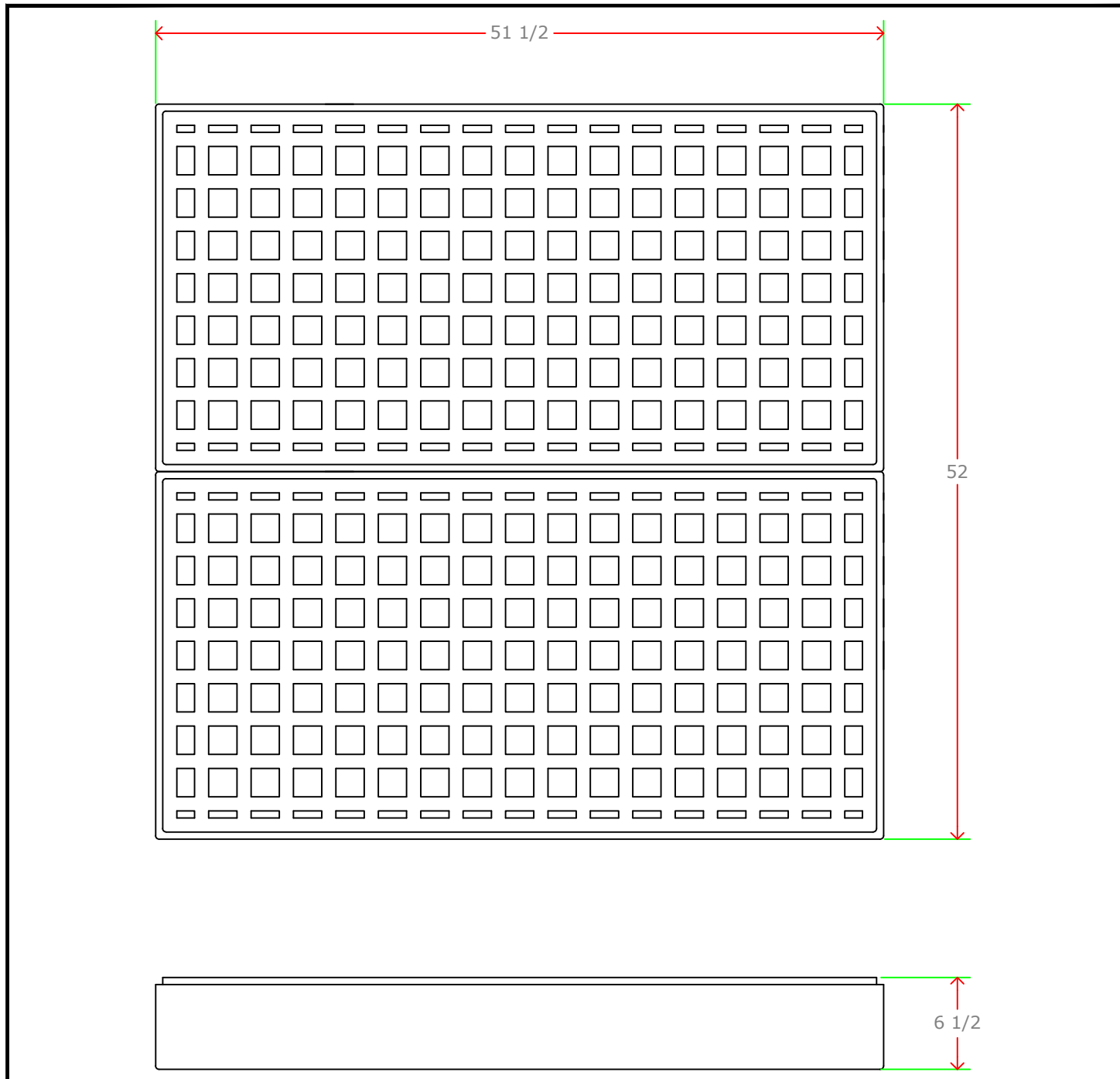

NOTICE: This drawing and its contents are for the specific use of GTP customers only. It is not to be duplicated or copied without expressed written consent or General Treatment Products, Inc. We reserve the right to modify this drawing without notice.