

# CHEMICAL MIXER INSTALLATION

1/4HP TEFC  
PREWIRED MOTOR  
W/8FT POWER CORD

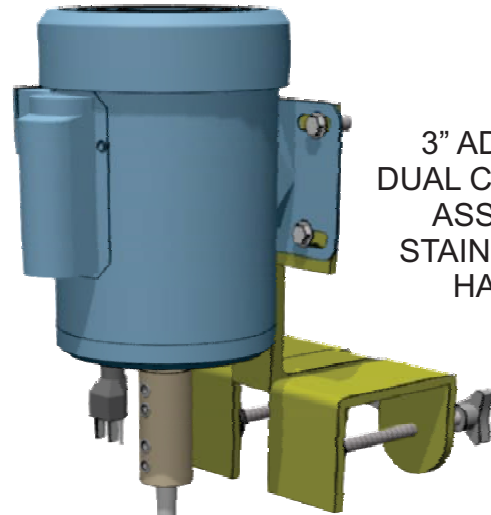

3" ADJUSTABLE  
DUAL CLAMP MOUNT  
ASSEMBLY W/  
STAINLESS STEEL  
HARDWARE

BRASS COUPLING  
W/SS SET SCREWS

1/2" DIA 316SS  
SHAFT

316SS 4" AXIAL  
IMPELLER  
(STAMPED  
PROPELLER)



**MATERIALS OF CONSTRUCTION:**  
CARBON STEEL, BRASS, 316 STAINLESS

<b>Capacity:</b>	N/A	Gallons
<b>Max Temp.:</b>	85	F
<b>Max Press.:</b>	N/A	PSI
<b>Weight:</b>	28	Lbs.
<b>Voltage.:</b>	115	VAC 1 Phs 60 Hz
<b>FLA.:</b>	1.3	amps

20	x	x
19	x	x
18	x	x
17	x	x
16	x	x
15	x	x
14	x	x
13	x	x
12	x	x
11	x	x
10	x	x
9	x	x
8	x	x
7	x	x
6	x	x
5	x	x
4	x	x
3	x	x
2	x	x
1	x	x

REV	DESCRIPTION	DATE
\	<b>PART DESCRIPTION</b>	
F	x	xx/xx/
E	x	xx/xx/
D	x	xx/xx/
C	x	xx/xx/
B	x	xx/xx/

General Treatment Products, Inc.  
PO Box 8697, Brea, CA 92822  
Phone: 714) 257-9165 <http://www.gtpcompany.com>  
Fax: 714) 257-9215 [customerservice@gtpcompany.com](mailto:customerservice@gtpcompany.com)

Date: 1/1/2017 Scale: NTS Rev.: A

Description:  
CHEMICAL MIXER INSTALLATION

Model:  
GD-C-0250E