

INDUSTRIAL GLYCOL FEED INSTALLATION

"0122020" GP SUCTION VALVE ASSEMBLY

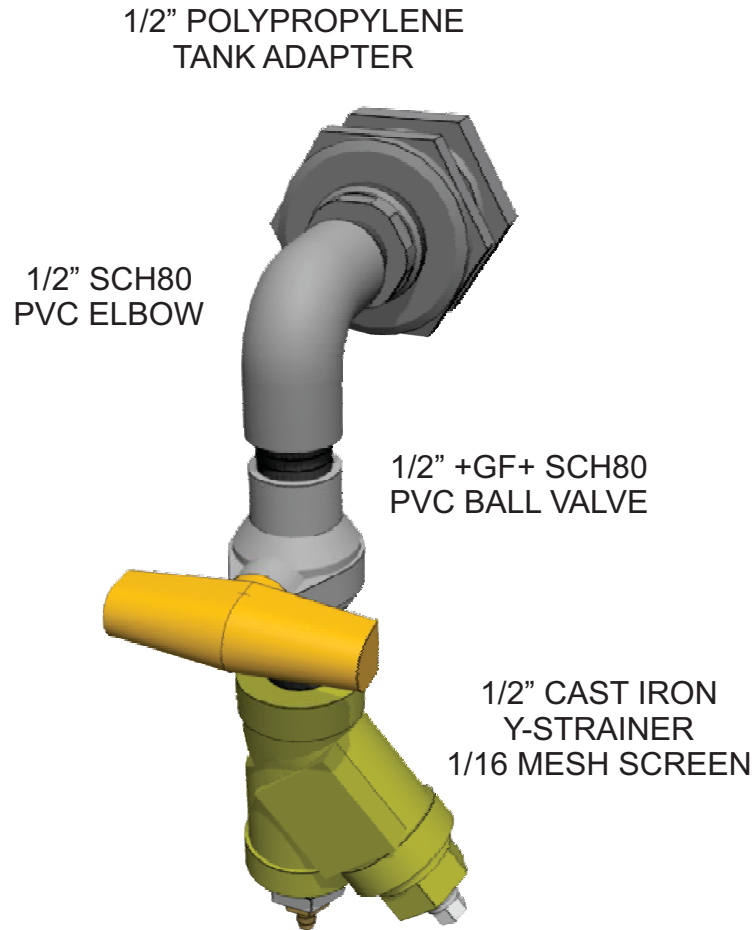

MATERIALS OF CONSTRUCTION:
CAST IRON, PVC, POLYPROPYLENE

Capacity:	N/A	Gallons
Max Temp.:	85	F
Max Press.:	N/A	PSI
Weight:	12	Lbs.
Voltage.:	N/A	VAC Phs Hz
FLA.:		amps

20	x	x
19	x	x
18	x	x
17	x	x
16	x	x
15	x	x
14	x	x
13	x	x
12	x	x
11	x	x
10	x	x
9	x	x
8	x	x
7	x	x
6	x	x
5	x	x
4	x	x
3	x	x
2	x	x
1	x	x

REV	DESCRIPTION	DATE
\	PART DESCRIPTION	
F	x	xx/xx/
E	x	xx/xx/
D	x	xx/xx/
C	x	xx/xx/
B	x	xx/xx/

General Treatment Products, Inc.
PO Box 8697, Brea, CA 92822
Phone: 714) 257-9165 <http://www.gtpcompany.com>
Fax: 714) 257-9215 customerservice@gtpcompany.com

Date: 1/1/2017 **Scale:** NTS **Rev.:** A

Description:
INDUSTRIAL GLYCOL FEED INSTALLATION

Model:
0122020