



General Treatment Products, Inc.

# Chemical Feed Systems

**GTP** has the capability to accommodate almost any chemical feed application. With a vast range of products at our disposal, we can build a complete turnkey system designed around your needs.

Provide us with your specifications and we can do the rest. Technical information, drawings, electrical, testing and training, it is all available to you at **GTP!**

Wall Mount, Tank & Stand Mount or Double Wall Containment, **GTP** can build it to order.

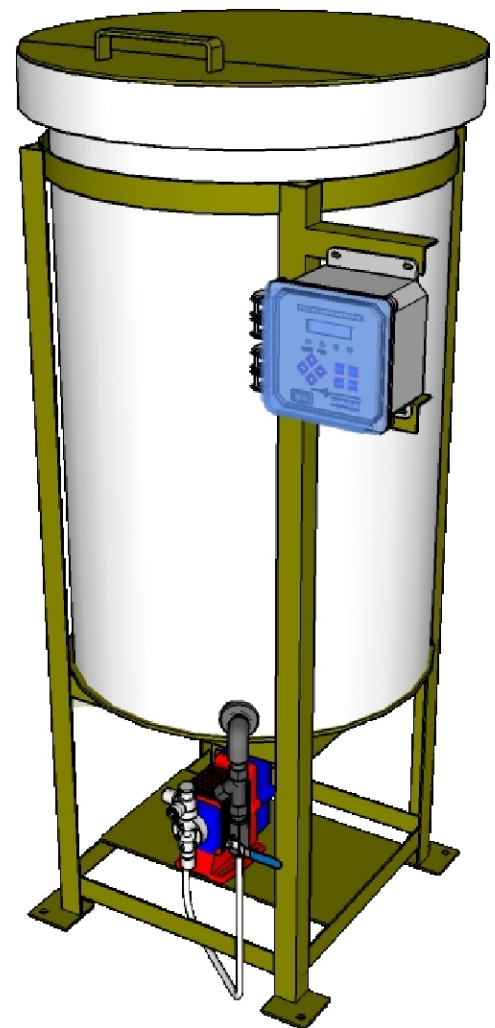
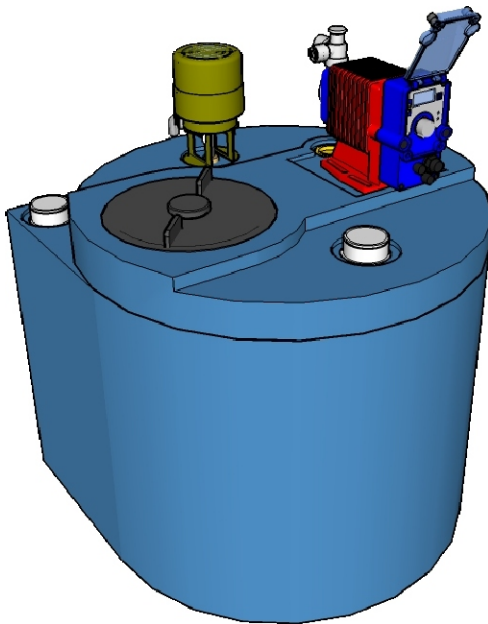

PO Box 8697, Brea, CA 92822-5697 ♦ Phone 714) 257-9165  
113 Viking Ave. Brea, CA 92821 ♦ Fax 714) 257-9215  
[www.gtpcompany.com](http://www.gtpcompany.com) ♦ [customerservice@gtpcompany.com](mailto:customerservice@gtpcompany.com)

# Chemical Feed Systems

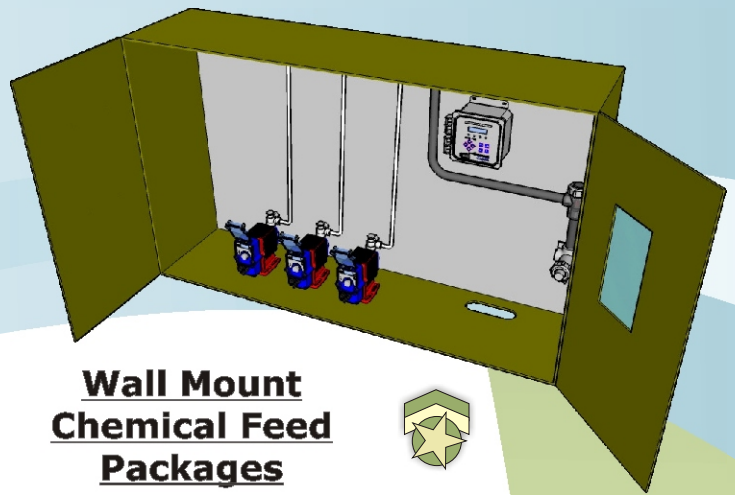
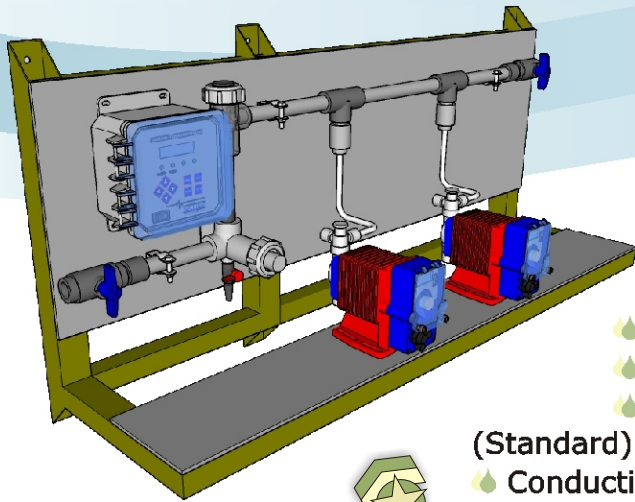

## Wall Mount Chemical Feed Packages

- ◆ 1-4 Pump Mounts
- ◆ Open or Enclosed Work Stations
- ◆ Double Wall Containment Tanks

### (Standard)

- ◆ Conductivity, pH or ORP Control
- ◆ Plumbing, Electrical and Mounts Supplied
- ◆ 2 Year Warranty

### Optional Features

- ◆ Customer Supplied Equipment
- ◆ Mixers
- ◆ Level Controls
- ◆ Spill Pallets / Skid Mounting

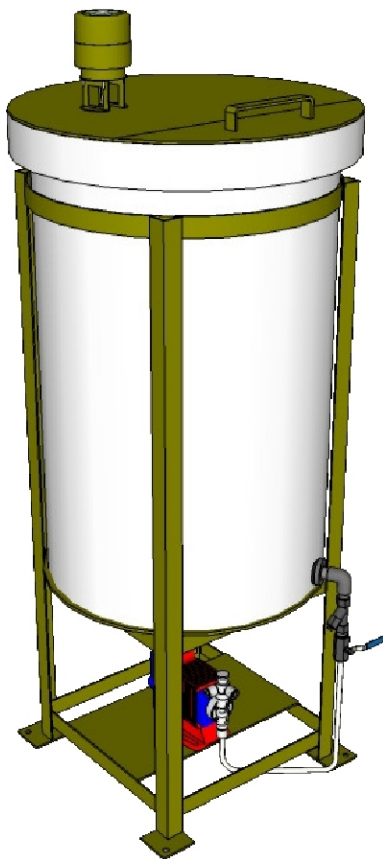

## Chemical Feed Packages

- ◆ Equipment Mounting Included
- ◆ Equipment Wiring and Testing Included
- ◆ Turnkey Systems
- ◆ 2 Year Warranty

### Optional Features

- ◆ Customer Supplied Equipment
- ◆ Mixers
- ◆ Level Controls
- ◆ Spill Pallets / Skid Mounting

