

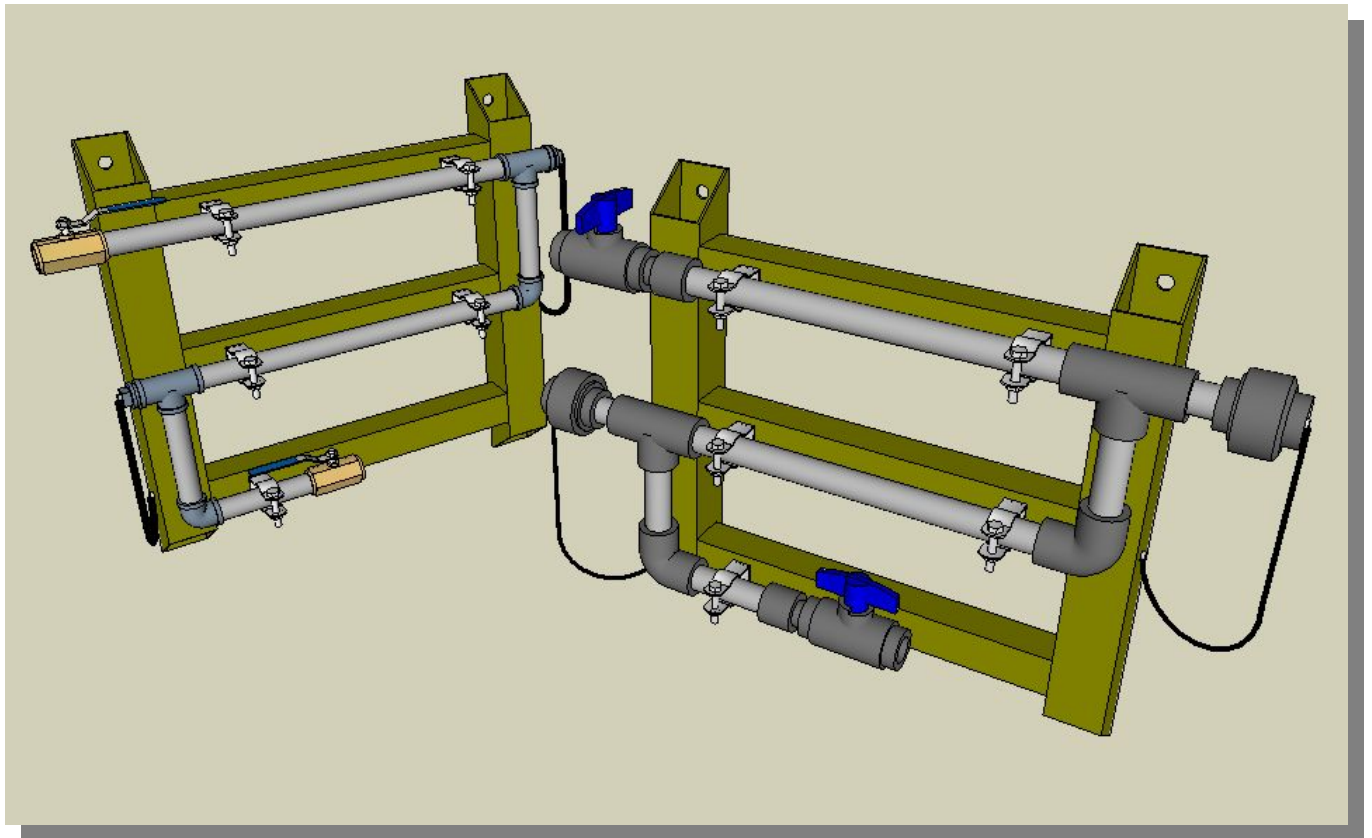

Corrosion Coupon Rack Operations & Maintenance Manual



Model, Serial Number and Other Information
is recorded for you on the back of this document.

Manufacturing: Bypass & Filter Feeders, Glycol Feed Packages, Tanks, Tank Stands, Chemical Batch Mixers, Corrosion Coupon Racks and Custom Systems

P.O. Box 8697, Brea, CA 92822-5697 ♦ Phone: 714) 257-9165
266 Viking Ave., Brea, CA 92821 ♦ Fax: 741) 257-9215
✉ www.gtpcompany.com ♦ customerservice@gtpcompany.com ☎

General Treatment Products, Brea, CA 92821, O&M Manual 01500030 Rev. D
Page 1 of 6

Contents	Page
1.0 Introduction	2
2.0 Warranty	2
3.0 Unpacking	3
3.1 Order Verification	3
4.0 Location and Environment	3
5.0 Installation	3
5.1 Connecting to system	4
5.2 Adjusting the Optional Flow Indicator	4
6.0 Pressure and Temperature Limitations	4
7.0 Routine Maintenance	4
8.0 Testing and Evaluation	
9.0 Parts Listing	5
10.0 Trouble Shooting	6
11.0 Notes	6
12.0 Product Label, Model Number, Serial Number and Pressure Settings	6

***** WARNING *****

- ⊛ ALL FASTENERS SHOULD BE PROPERLY SECURED BEFORE OPERATION AS THEY MAY BE LOOSENED IN TRANSIT
 - ⊛ PERSONNEL SAFETY PRACTICES SHOULD APPLY AT ALL TIMES
 - ⊛ SAFETY GLASSES OR FACE SHIELDS AND GLOVES SHOULD BE WORN
 - ⊛ CLOSE ISOLATION VALVE AND RELEASE PRESSURE BEFORE SERVICING ANY COMPONENTS ON THE SYSTEM
 - ⊛ ALL LIQUIDS IN SYSTEM SHOULD BE DRAINED BEFORE SERVICING

⊛ **1.0 Introduction**

Thank you for choosing General Treatment Products Corrosion Coupon Rack. This industrial, assembly comes complete and ready to install. In this document we explain the basics for locating, installing and operating this corrosion coupon rack. For further information, please contact us at customerservice@gtpcompany.com or call us at the phone number on the cover.

⊛ **2.0 Warranty**

General Treatment Products Corrosion Coupon Racks are guaranteed for two years from date of shipment against manufacturing defects in material and workmanship that develop in the service for which they are designed. We will repair or replace a defective part of this system when returned to our factory with freight prepaid; providing that the part is found to be defective upon inspection. We assume no liability for labor and/or other expenses in making repairs or adjustments.

★ 3.0 Unpacking

Upon receipt of order, inspect package thoroughly. In the event damage occurred in transit you must notify the freight company within **3-5 days of receipt of order**. Once system is inspected for damage and received in good condition, store indoors until installing.

★ 3.1 Order Verification

In order to verify receipt of correct product, use the following table and model number to identify the contents.

MODEL						
P	CR	2	07	-SVP		
<div style="border: 1px solid black; width: 100%; height: 100%;"></div>					OPTIONS	
					PB	Grey PVC Backboard
					SVP	PVC Sample Valve
					YSP	PVC Y-Strainer
					FI10	Flow Indicator, 10GPM
					FCP05	Flow Control Valve, PVC, 5GPM
					FCB05	Flow Control Valve, Brass, 5GPM
					FCS05	Flow Control Valve, Stainless Steel, 5GPM
					Note: See pricing for complete options list	
					LINE SIZE	
					07	3/4 Pipe Size
					10	1" Pipe Size
					# OF SAMPLES	
					1	1 Point Coupon Rack
					2	2 Point Coupon Rack
3	3 Point Coupon Rack					
4	4 Point Coupon Rack					
5	5 Point Coupon Rack					
6	6 Point Coupon Rack					
BASE						
CR	Coupon Rack					
MATERIAL						
P	PVC Polyvinylchloride					
CP	CPVC Chlorinated Polyvinylchloride					
CS	Carbon Steel					
SS	Stainless Steel, 316					

Note: Not all options and sizes available on all systems.

★ 4.0 LOCATION AND ENVIRONMENT

Although there is no electrical, environment may change the results of the sample corrosion rate. Excessive exposure to sunlight, weather or other exposure can result in changes in corrosion rate.

★ 5.0 INSTALLATION

Once location is decided on, coupon rack need to be securely mounted to wall studs. **Be sure that anchoring bolts comply with local building codes.** At this time it is best to run coupon rack on new systems for approximately one week. All new piping systems have residual chemicals, oils, etc... that need to be flushed out before starting sample corrosion testing. After initial flushing, close isolation valves and install corrosion samples. Before opening valves and starting corrosion testing be sure to note sample material and installation date on tags provided.

★ 5.1 CONNECTING TO SYSTEM

Corrosion coupon racks should be installed within 10 to 30 feet of system. Coupon rack flow should have similar characteristics as system. Corrosion rate can be increased by erosion.

★ 5.2 ADJUSTING THE FLOW INDICATOR

The flow indicator (optional) can be adjusted by regulating the inlet and outlet isolation valves. This option may be purchased with an adjustable gate valve. By restricting the flow through the coupon rack the sediment in the system will not erode the sample coupon.

★ 6.0 PRESSURE AND TEMPERATURE LIMITATIONS

MATERIAL	MAXIMUM SHORT TERM TEMPERATURE	MAXIMUM OPERATING TEMPERATURE	MAXIMUM OPERATING PRESSURE
Polyethylene (PE)	160°F/69°C	85°F/36°C	N/A
Polyvinylchloride (PVC)	140°F/60°C	85°F/36°C	100PSI/6.9BAR
Chlorinated Polyvinylchloride (CPVC)	180°F/77°C	85°F/36°C	100PSI/6.9BAR
Polypropylene (PP)	180°F/77°C	85°F/36°C	100PSI/6.9BAR
Carbon Steel (CS)	200°F/93°C	85°F/36°C	150PSI/10.3BAR
Cast Iron (CI)	200°F/93°C	85°F/36°C	150PSI/10.3BAR
Brass (BR)	200°F/93°C	85°F/36°C	150PSI/10.3BAR
Stainless Steel (SS)	200°F/93°C	85°F/36°C	150PSI/10.3BAR

Note: Minimum Fluid Temperature is 50°F/10°C.

★ 7.0 ROUTINE MAINTENANCE

Routine maintenance in this section is referred to as checking once a month until a maintenance schedule can be determined. **All fasteners should be checked for proper operations.** Maintenance and care will depend upon the usage and environment in which the coupon rack is subject to. Once the corrosion sample has been installed, periodically check for leaks and or tampering is all that is needed.

Please contact your Water Doctor or chemical supplier for Coupon Test duration and or inspection.

❖ 8.0 PARTS LISTING

In the following diagrams, the systems are shown with tables itemizing parts that may be replaced in the field. If further breakdown is needed, call us for assistance.

PART	PVC	CPVC	CS	SS
Coupon Holder, 3/4"	PCH07	CPCH07	CSCH07	SSCH07
Coupon Holder, 1"	PCH10	CPCH10	CSCH10	SSCH10
Isolation Valve, 3/4"	0130050	0130051	0130052	0130053
Isolation Valve, 1"	0130055		0130056	
Mounting Rack	RCK01			
	RCK02			
	RCK03			
	RCK04			
	RCK05			
	RCK06			
Pipe Housing, 1POINT, 3/4"	0130001	0130010	0130020	0130030
Pipe Housing, 2POINT, 3/4"	0130002	0130011	0130021	0130031
Pipe Housing, 3POINT, 3/4"	0130003	0130012	0130022	0130032
Pipe Housing, 4POINT, 3/4"	0130004	0130013	0130023	0130033
Pipe Housing, 5POINT, 3/4"	0130005	0130014	0130024	0130034
Pipe Housing, 6POINT, 3/4"	0130006	0130015	0130025	0130035
Sample ID Tag	SMPTG001			

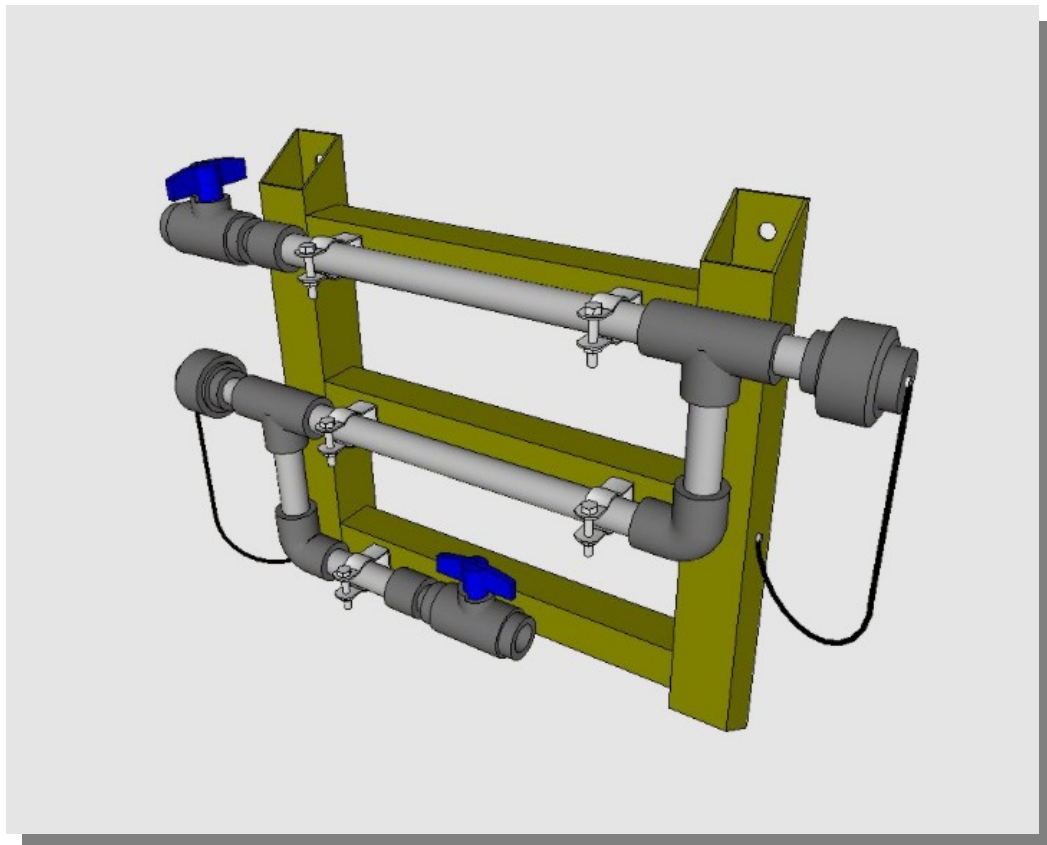

★ 9.0 TESTING AND EVALUATION

Once duration for testing has expired (determined by others) isolate coupon rack and remove samples. Included with your corrosion sample order was a evaluation test report. This report and brief test duration is all that is needed for a proper evaluation. If you no longer have the initial paperwork, please contact your source and request a copy. These coupon sample can be returned to GTP or sent directly to:

Metal Samples Inc.
P.O. Box 8
Munford, AL 36268
Phone 256-358-4202 Fax 256-358-4515

<http://www.alspi.com/>

★ 10.0 TROUBLE SHOOTING

If you are still having problems, contact us at repairs@gtpcompany.com, or you can call us at the number on the front of the Instruction manual.

★ 11.0 NOTES

★ 11.0 PRODUCT LABEL

Model:

Serial Number:
