

GTP "GP" Series

INDUSTRIAL GLYCOL FEED PACKAGE

Specification 01600030 Rev. E

Written: April 2009

Page 1 of 2



★ 1.0 DESCRIPTION

1.1 AUTOMATIC INDUSTRIAL GLYCOL FEED PACKAGE: Shall be manufactured by General Treatment Products, or approved equal and consist of a polyethylene tank, hinged polyethylene cover, carbon steel frame, lockable NEMA 4X control panel, low level float switch, 1/3HP open motor bronze gear pump with internal pressure relief, pressure switch, pressure relief valve, check valve, PVC plumbing and reinforced butyl rubber hose assemblies.

★ 2.0 MATERIALS

2.1 TANK AND FRAME: Polyethylene tank shall be industrial grade with a minimum wall thickness of .125". Shoebox type lid shall be 1/3 hinged with aluminum hinge and rivets. Tank frame shall be constructed of carbon steel with oil based enamel coating, fixed bracing for control panel, plumbing and gear pump. Standard sizes include:

- 15 gallon tank and frame
- 30 gallon tank and frame
- 55 gallon tank and frame
- 100 gallon tank and frame

2.2 GEAR PUMP: Gear pump shall be close coupled with internal pressure relief valve. Gear pump shall be capable of a minimum 1.3 gallons per minute against 100 PSI. Motor shall be 115 VAC, 1 Phase, 60 Hertz, open drip proof type and be hard wired to pressure control circuit. Optional Pump Outputs Include:

- 3.0GPM at 100PSI gear pump

2.3 PRESSURE SWITCH: Pressure switch and control circuit shall be designed for pressures as shown below. Pressure switch shall turn on pump on falling pressure and turn off pump on rising pressure. Standard pressure range is Code 1, 10-45 cut-in, 20-50 cut-out, 10-30 pressure differential. Optional Pressure Ranges Include:

- Code 2, 40-80 cut-in, 65-100 cut-out, 20-40 pressure differential
- Code 3, 3-10 cut-in, 9-30 cut-out, 6-20 pressure differential

2.4 CONTROL PANEL: Polycarbonate NEMA 4X lockable control panel shall be of ample size needed for equipment and servicing of electrical components. With the exception of electrical disconnect, all components shall be installed behind clear viewing panel and have locking hasp to deter tampering. Wiring diagram shall be color coded for easy trouble shooting. All internal wiring shall be of ample gauge for supply voltage and amp draw. Controls shall be, but not limited to, main power/disconnect switch and indicator, pump manual/off/auto switch and indicator and red low level indicator. All indicator lights shall be LED and designed for continuous use.

2.5 PRESSURE RELIEF VALVE: Brass pressure relief valve shall have adjustment handle and have brass seat and elastomer seal. Valve shall be of ample size to handle full pump output and be two port design.

2.6 CHECK VALVE: Back flow check valve shall be tapered body design with an enlarged valve chamber to reduce valve chatter and clogging. Valve shall be constructed of bronze and stainless steel and have a raised radius valve seat for positive seal.

2.7 LOW LEVEL SWITCH: Stainless steel low level switch with carbon steel tank fitting shall be interlocked with 5 AMP relay and stop glycol feed pump when liquid reaches

P.O. Box 8697, Brea, CA 92822-5697 ♦ Phone: 714) 257-9165

266 Viking Ave., Brea, CA 92821 ♦ Fax: 714) 257-9215

www.gtpcompany.com ♦ customerservice@gtpcompany.com

GTP "GP" Series

INDUSTRIAL GLYCOL FEED PACKAGE

Specification 01600030 Rev. E

Written: April 2009

Page 2 of 2



factory set level. Low level circuit will then turn on RED indicator light and initiate 115 VAC 10 amp circuit.

2.8 OPTIONAL FEATURES: Select options from below.

- Code "D" Dual Pumps with dual manifolds, control switches and indicators
- Code "DGL" Digital glycol feed controller, audible alarm & dry contact
- Code "HM" High temperature manifold
- Code "AL" 95 decibel audible alarm and silence switch
- Code "DC" Remote dry contact on low level
- Code "MX" Batch mixer, mount bracket and control switch
- Code "HL" High level indicator
- Code "EMS05" Dry contact control box for up to 5 sensing points

★ 3.0 WARRANTY: General Treatment Products Gly-Pack Feed Systems are guaranteed for two years from date of shipment against manufacturing defects in material and workmanship which develop in the service for which they are designed. We will repair or replace a defective part of this system when returned to our factory with freight prepaid; providing that the part is found to be defective upon inspection. We assume no liability for labor and/or other expenses in making repairs or adjustments.

★ 4.0 DRAWING, DIMENSIONS & WEIGHTS: Model shown in drawing is GP55-E4-1. Dimensions are +/- 1/8". Weights are approximate (See pricing for details)

KEY	GP15-E4-1	GP30-E4-1	GP55-E4-1	GP100-E4-1
A	24 3/8"	26 13/16"	31 3/16"	35 11/16"
B	41 1/8"	48 5/16"	54 5/16"	66 13/16"
C	18 1/8"	18 1/8"	18 1/8"	18 1/8"
D	13 1/4"	18 1/4"	23 1/4"	29 1/4"
WEIGHT	108 lbs.	129 LBS.	148 LBS.	215 LBS.

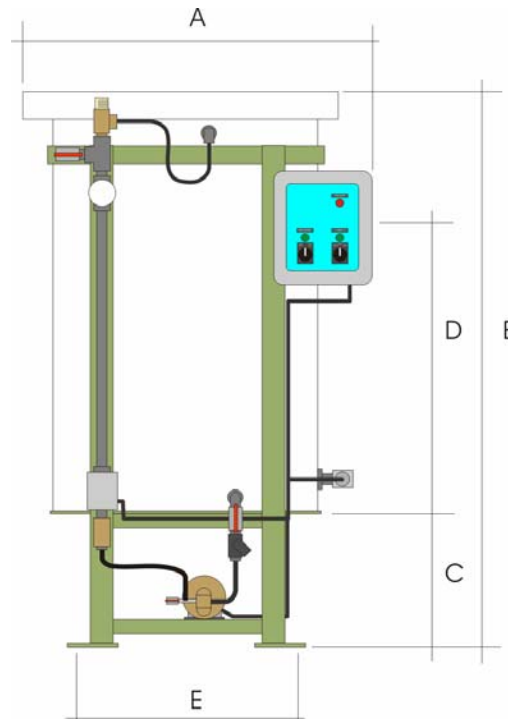

P.O. Box 8697, Brea, CA 92822-5697 ♦ Phone: 714) 257-9165
 266 Viking Ave., Brea, CA 92821 ♦ Fax: 714) 257-9215

🌐 www.gtpcompany.com ♦ customerservice@gtpcompany.com 📠